

## Transport Scotland



### Roads for All Good Practice Guide for Roads

July 2013



© Crown copyright 2013

You may re-use this information (not including logos) free of charge in any format or medium, under the terms of the Open Government Licence. To view this licence, visit <http://www.nationalarchives.gov.uk/doc/open-government-licence/> or write to the Information Policy Team, The National Archives, Kew, London TW9 4DU, or e-mail: <mailto:psi@nationalarchives.gsi.gov.uk>.

This document/publication is also available on our website at <http://www.transport.gov.scot>

ISBN: 978-1-908181-72-5  
The Scottish Government  
St Andrews House  
Edinburgh  
EH3 3DG  
Published by the Scottish Government, July 2013

# Amendments sheet

Date	Amendment
July 2013	<p data-bbox="507 651 1369 723"><u>Chapter 2: Disability Discrimination Legislation and Disabled People</u></p> <ul data-bbox="518 734 1337 768" style="list-style-type: none"> <li data-bbox="518 734 1337 768">• Section 2.1: text updated regarding the Equality Act (2010)</li> </ul> <p data-bbox="507 824 1217 857"><u>Chapter 3: Meeting the Needs of Disabled People</u></p> <ul data-bbox="518 869 1430 981" style="list-style-type: none"> <li data-bbox="518 869 1430 936">• Section 3.2: website address added for Scottish Disability Equality Forum and text updated regarding the Equality Act (2010)</li> <li data-bbox="518 947 1273 981">• Section 3.8: introduction of Accessibility Audit System</li> </ul> <p data-bbox="507 1037 922 1070"><u>Chapter 4: Design Standards</u></p> <ul data-bbox="518 1081 1430 1966" style="list-style-type: none"> <li data-bbox="518 1081 1401 1149">• Section 4.1.6: text added regarding access to and layout of bus lay-bys</li> <li data-bbox="518 1160 1385 1227">• Section 4.1.7: text added regarding access to and layout of in-line bus stops, with reference to raised boarding kerbs</li> <li data-bbox="518 1238 1201 1272">• Section 4.1.8: text added regarding puffin crossings</li> <li data-bbox="518 1283 1273 1317">• Section 4.1.11: DMRB reference corrected to TD 36/93</li> <li data-bbox="518 1328 1201 1361">• Section 4.2.2: text added regarding puffin crossings</li> <li data-bbox="518 1373 1026 1406">• Section 4.3.2: number added to table</li> <li data-bbox="518 1417 1401 1451">• Section 4.4.2: text added regarding shared pedestrian/cycle routes</li> <li data-bbox="518 1462 1430 1529">• Section 4.5.6: text added indicating the correct placement of lighting columns</li> <li data-bbox="518 1541 1430 1608">• Figures 1, 2a, 2b, 3a, 3b: lay-by signage and road markings revised for accessible bay to be in accordance with TSRGD</li> <li data-bbox="518 1619 1353 1686">• Figure 4: bus lay-by detail amended to include hard strip as per DMRB</li> <li data-bbox="518 1697 1257 1731">• Figure 5: note added regarding position of bus stop flag</li> <li data-bbox="518 1742 1201 1776">• Figure 6: controlled crossing changed to puffin type</li> <li data-bbox="518 1787 1201 1821">• Figures 7a and 7b: minimum crossing widths added</li> <li data-bbox="518 1832 1217 1865">• Figure 11: controlled crossing changed to puffin type</li> <li data-bbox="518 1877 1409 1944">• Figure 15: vehicle give way markings corrected and access context added</li> <li data-bbox="518 1955 1401 2022">• Figure 25: diagram amended to indicate a variety of tonal contrast examples</li> </ul>

July 2013 contd.

- Figure 26b: road markings revised for accessible on-street parallel parking bay to be in accordance with TSRGD
- Figure 29, 30, 31: tactile paving and double transition kerbs deleted from layout for emergency telephone access

#### Chapter 5: Construction, Operation and Maintenance

- Figure 32: controlled crossing changed to puffin type
- Section 5.3.3: text revised regarding projections over footways
- Section 5.3.4: text revised regarding obstructing footways
- Section 5.3.5: text revised regarding legalities of unauthorised use of accessible parking bays
- Section 5.4.1: text revised regarding foliage overhanging the footway

#### Chapter 6: Accessibility Audit System

- Accessibility Audit System introduced

#### Appendices

- Appendix A: reference added to on-line directory of local Access Panels, and default adoption of GPG standards clarified in diagram
- Appendix B: further reading and references updated

December 2018

#### Chapter 3: Meeting the Needs of Disabled People

- Section 3.2: updates made to reflect change in organisation name from SDEF to Disability Equality Scotland
- Sections 3.6 and 3.7: updates made to reflect changes in retention of substandard details
- Section 3.8: updates to reflect Accessibility Audit System being superseded by DMRB HD 42/17

#### Chapter 4: Design Standards

- Section 4.1.9: references updated
- Section 4.1.13: references updated
- Section 4.1.15: references updated
- Section 4.1.16: references updated
- Section 4.5.5: references updated

December 2018  
contd.

Chapter 5: Construction, Operation and Maintenance

- Section 5.4.2: text regarding withdrawn standard HD 40/01 has been deleted

Chapter 6: Accessibility Audit System

- Chapter deleted, refer instead to requirements of Section 3.8.

Appendices

- Appendix A: reference updated to on-line directory of Access Panels
- Appendix B: further reading and references updated

# CONTENTS

## COMMENTS

## ACKNOWLEDGEMENTS

<b>1</b>	<b>INTRODUCTION</b>	<b>2</b>
<b>2</b>	<b>DISABILITY DISCRIMINATION LEGISLATION AND DISABLED PEOPLE</b>	<b>4</b>
	2.1 Legislative Background	4
	2.2 Disabled People	5
<b>3</b>	<b>MEETING THE NEEDS OF DISABLED PEOPLE</b>	<b>6</b>
	3.1 Introduction	6
	3.2 Involvement	6
	3.3 Access Champion	6
	3.4 Equality Impact Assessments and Test of Reasonableness	6
	3.5 Existing Guidance and Standards	7
	3.6 Implementation	7
	3.7 Good Practice Guide Departures from Standard	7
	3.8 Accessibility Review	7
<b>4</b>	<b>DESIGN STANDARDS</b>	<b>8</b>
	4.1 Road Link Features	8
	4.1.1 Introduction	8
	4.1.2 Lay-bys	8
	4.1.3 Parking Lay-bys (Type A)	8
	4.1.4 Parking Lay-bys (Type B)	8
	4.1.5 Parking Lay-bys (Type A Lay-by with Trading Facility)	9
	4.1.6 Bus Lay-bys	10
	4.1.7 Bus Stops (In-line)	10
	4.1.8 Controlled Pedestrian Crossings	11
	4.1.9 Dropped Kerbs	12
	4.1.10 Footway Width	13
	4.1.11 Headroom	14
	4.1.12 Crossfall	14
	4.1.13 Landings (Rest Points)	15
	4.1.14 Shared Pedestrian/Cycle Routes	16
	4.1.15 Surfacing Materials	16
	4.2 Junctions	16
	4.2.1 Introduction	16
	4.2.2 Signalised Junctions	16
	4.2.3 Major/Minor Priority Junctions	17
	4.2.4 Roundabouts	19
	4.2.5 Vehicle Access to the Road (Vehicle Footway Crossovers)	19
	4.3 Steps and Ramps	21
	4.3.1 Introduction	21
	4.3.2 Ramps	21
	4.3.3 Steps – Dimensions	22
	4.3.4 Steps – Tapered Risers	23
	4.3.5 Steps – Nosings	23
	4.3.6 Handrails	24
	4.4 Tactile Surfaces	25
	4.4.1 Introduction	25
	4.4.2 Tactile Surfaces	25
	4.5 Street Furniture/Ancillary Equipment	31

---

4.5.1	Introduction	31
4.5.2	Street Furniture	31
4.5.3	Designing for Tonal Contrast	33
4.5.4	Seating	34
4.5.5	Signage	34
4.5.6	Lighting	34
4.5.7	Rest Areas	35
4.5.8	Parking	35
4.5.9	Toilets	37
4.5.10	Emergency Telephones	38
<b>5</b>	<b>CONSTRUCTION, OPERATION AND MAINTENANCE</b>	<b>42</b>
5.1	Introduction	42
5.2	Construction	42
5.2.1	Traffic Management	42
5.2.2	Traffic Management Design	42
5.2.3	Construction Quality Control	43
5.3	Operational Issues	44
5.3.1	Advertising Boards	44
5.3.2	Pavement Cafés	45
5.3.3	Projections	46
5.3.4	Obstructing the Footway	46
5.3.5	Unauthorised Use of Accessible Bays	46
5.4	Maintenance	47
5.4.1	Foliage	47
5.4.2	Footway Surfaces	47
	<b>APPENDIX A – EQUALITY IMPACT ASSESSMENT AND TEST OF REASONABLENESS - GUIDANCE FOR PROJECT TEAMS</b>	<b>49</b>
	<b>APPENDIX B – FURTHER REFERENCES</b>	<b>51</b>

## COMMENTS

As with other design standards and advice documents, the Good Practice Guide will be updated regularly to take account of experience. Any comments on the document should be forwarded to the following address:

Transport Scotland  
Standards Branch  
Buchanan House  
58 Port Dundas Road  
Glasgow  
G4 0HF

Email: [info@transport.gov.scot](mailto:info@transport.gov.scot)

## **ACKNOWLEDGEMENTS**

The Good Practice Guide has been produced by Transport Scotland for use on Scotland's trunk road and motorway network. It is commended to all Scottish local road authorities.

Transport Scotland is grateful to Halcrow Group Limited and to the Roads For All Forum for all their assistance and helpful advice in producing the Guide. In particular the following organisations are thanked for their input:

Mobility and Access Committee for Scotland (MACS);  
Scottish Disability Equality Forum (SDEF);  
Scottish Accessible Transport Alliance (SATA);  
Inclusion Scotland;  
Action on Hearing Loss;  
Scottish Council on Deafness (SCOD);  
Society of Chief Officers for Transportation in Scotland (SCOTS);  
Confederation of Passenger Transport (CPT);  
Association of Chief Police Officers in Scotland (ACPOS) and  
People Friendly Design.

Page intentionally left blank

## 1

# INTRODUCTION

This Good Practice Guide contains Transport Scotland's requirements for inclusive design in the construction, operation and maintenance of road infrastructure. Inclusive design is an approach which aims to create environments which can be used by everyone regardless of age or disability.

The Guide provides practitioners with current international good practice and advice on providing for the needs of people with sensory, cognitive and physical impairments, within the road environment. Where the guidance and design standards presented here conflict with the 'Design Manual for Roads and Bridges' (DMRB), this Good Practice Guide takes precedence. For implementation and Departures from Standard refer to Section 3.6 and Section 3.7.

The Good Practice Guide is targeted at everyone who makes design and management decisions which affect the road network. This includes external consultants and contractors as well as Transport Scotland staff.

Production of the Good Practice Guide is one of the objectives of Transport Scotland's Trunk Road Disability Equality Scheme and Action Plan, 'Roads for All', published in December 2006.

The Action Plan sets out the following objectives:

- To make Scotland's trunk road network safer and more accessible for all users by the removal of barriers to movement along and across trunk roads;
- To develop all professional and technical staff involved in the design, construction, operation, and maintenance of the trunk road network to recognise and understand the needs of disabled people;
- To ensure the design, construction, operation, and maintenance of the trunk road network meets the needs of disabled people through the involvement of disabled people in the development of good practice guidance;
- To make facilities and services more accessible from the trunk road network;
- To make journeys secure and comfortable for all by working with other service providers and utilising appropriate technology;
- To promote journeys by public transport by working with local authorities, regional transport partnerships and operators to improve access, facilities and information at bus stops etc. directly accessed from trunk roads.

It should be noted that in order to take full account of the needs of disabled people legislation permits treating disabled people more favourably than others.

Page intentionally left blank

## 2

## DISABILITY DISCRIMINATION LEGISLATION AND DISABLED PEOPLE

### 2.1 Legislative Background

The Disability Discrimination Act (1995) placed a duty on employers, educators and service providers to make reasonable adjustments to avoid discriminating against disabled people. This included making adjustments to physical features which act as barriers to access for disabled people. Public functions were not covered by this Act.

The Disability Discrimination Act (2005) amended the 1995 Act and extended the principles of Part III, which prohibited discrimination in the provision of goods, facilities and services and premises, to the delivery of public authority functions. This amendment also brought in new duties for public authorities, including Transport Scotland, to actively promote disability equality.

On 5 April 2011, the Equality Act (2010) introduced a new public sector general equality duty. This general equality duty requires Scottish public authorities to pay “due regard” to the need to:

- Eliminate unlawful discrimination, victimisation and harassment;
- Advance equality of opportunity;
- Foster good relations.

These requirements apply across the “protected characteristics” of age; disability; gender reassignment; pregnancy and maternity; race; religion and belief; sex and sexual orientation and to a limited extent to marriage and civil partnership. This single duty replaced the three previous duties relating to race, disability and gender equality.

The equality duty is in two parts – the general duty in the Equality Act (2010) itself, and specific duties which are placed on some public authorities by Scottish Ministers. Specific duties are intended to assist public authorities in meeting their general duty. In particular, the specific duties set out what public bodies should do to plan, deliver and evaluate actions to eliminate discrimination and promote equality, and to report on the activity.

The Equality and Human Rights Commission (EHRC) came into being on 1 October 2007. It combines the responsibilities and powers of the three previous equality commissions - Commission for Racial Equality (CRE), the Disability Rights Commission (DRC) and the Equal Opportunities Commission (EOC) for promoting racial, disability and gender equality in Britain. The EHRC covers England, Scotland and Wales, but not Northern Ireland. The Commission in Scotland is there to see its aims are delivered in a way that responds to Scottish needs. The team is based in Edinburgh and Glasgow and works closely with the Scotland Commissioner.

Codes of practice are available from the EHRC to assist public authorities in meeting their duties. The guidance covering planning, buildings and streets is particularly relevant.

## 2.2 Disabled People

In the 2001 census 20 per cent of the population were reported to have some form of disability. This includes people with sensory and cognitive impairments, as well as people with mobility impairments, including wheelchair users. Disabled people have a wide spectrum of different and sometimes conflicting needs. Inclusive design sets out to give due consideration to all of these needs and the other demands on a project, including cost, to strike the best balance for all users of an environment.

The average age of the population is increasing. As there is a strong correlation between age and disability, it is important that we design for as wide a group as possible to ensure disabled people can play a full part in society.

For most disabled people the private car is the only form of transport that is accessible and this is likely to continue to be the case no matter how accessible public transport becomes. Yet there are barriers created by the management and operation of our roads and parking systems which restrict access for disabled people. A lack of suitable parking facilities and a lack of dropped kerbs on key pedestrian routes are two of the physical constraints to the use of private vehicles for many disabled people.

Research findings from 'Improved Public Transport for Disabled People' (Scottish Executive, 2006) identified the biggest difference between disabled adults and non-disabled adults as being not the way disabled people make a journey or the reasons for their trip, but the fact that disabled people are far less likely to make a trip at all. In light of the reduced number of trips made, disabled adults were less likely to report participating in a wide range of activities compared with non-disabled adults. There has been little or no change in the barriers to travel that disabled people face since earlier research on the subject was published in 1998. No one single "solution" is likely to make a difference to the travel opportunities of disabled people in Scotland.

Many disabled people, although eligible for concessionary travel on buses and trains, cannot actually use such forms of transport largely due to the connecting journey between home and the bus stop or train station. The pedestrian environment has an important part to play in improving access to public transport. This is backed up by the research findings from 'Older People: Their Transport Needs and Requirements' (Department for Transport, 2001).

Older people worry more about safety in the pedestrian environment and, statistically, they are more severely injured, take longer to recover and suffer greater psychological impact from an accident than younger people. However travel is important for this group to access entertainment, to participate in society and generally to be independent.

As people grow older they become more reliant on public transport but evidence suggests many experience difficulties accessing and using buses and trains due to the poor condition of footways, inadequate crossing facilities and a difficulty in boarding and alighting from public transport vehicles.

This Good Practice Guide means to make a difference to the quality of life of a significant proportion of our population.

# 3

## MEETING THE NEEDS OF DISABLED PEOPLE

### 3.1 Introduction

This section describes key elements in the process which should be followed when designing a road improvement to ensure the needs of disabled people are integrated into the design.

### 3.2 Involvement

The involvement of disabled people is a key element of inclusive design and is a requirement of the Equality Act (2010).

Local Access Panels include disabled people with an interest in improving access to the built environment and can be useful groups to involve during the development of road projects. Transport Scotland involved Access Panels from across Scotland in the development of its Trunk Road Disability Equality Scheme and Action Plan. Disability Equality Scotland acts as an umbrella body for most Access Panels in Scotland and operates an online directory of local Access Panels (see [www.disabilityequality.scot](http://www.disabilityequality.scot) and [www.accesspanelnetwork.org.uk](http://www.accesspanelnetwork.org.uk)).

### 3.3 Access Champion

Regardless of the scale of the project, a member of the Design Team must champion the needs of non-motorised users and disabled people reviewing the proposals at key stages to ensure that aims are being met. On large projects this may be an independent expert and on smaller projects this role may be only one part of an individual's wider brief. This role is a mandatory requirement for trunk road projects and the individual is to be formally appointed by letter from the beginning of the detailed design (DMRB Stage 3) to construction and commissioning.

The person in this role should have detailed technical knowledge and understanding of the diverse and sometimes conflicting needs of disabled people within environments. This includes the needs of everyone, from people with sensory and cognitive impairments to people with mobility impairments, including wheelchair users. To give balanced recommendations the Access Champion must also have an appreciation of other users' needs including children and older people. An understanding of road construction and design is also important in order to understand the other demands on a project.

### 3.4 Equality Impact Assessments and Test of Reasonableness

Transport Scotland, like all public authorities, has an obligation under the terms of the Equality Act (2010) to carry out Equality Impact Assessments (EqIA) of the effect on disabled people of all its functions and actions. This process includes identifying and assessing opportunities to make a positive impact on the lives of disabled people as well as assessing ways to remove, avoid or mitigate barriers or other negative effects on disabled people. Transport Scotland must give due consideration to many competing demands in the design, construction, operation and maintenance of the trunk road network and in spending a finite budget. Therefore, Tests of Reasonableness will be carried out on the different types of barrier to access. Quantifying the benefit of addressing a barrier and the cost involved are key factors in establishing reasonableness. However, it should be noted that the Equality Act (2010)

permits authorities to treat disabled people more favourably. For more details on EqIA and Tests of Reasonableness refer to Appendix A.

### **3.5 Existing Guidance and Standards**

The following layout drawings and text represent current international good practice for inclusive design in the road environment. The key references are the DMRB and 'Inclusive Mobility' (Department for Transport, 2005) but there are also a number of other documents referred to. This guidance is laid out in a similar order to the DMRB to assist designers when using the document.

### **3.6 Implementation**

This Good Practice Guide must be used forthwith for the procurement of trunk road works at any stage from conception through design to completion of construction except where the procurement of such works has reached a stage which (in the opinion of Transport Scotland) use of this Good Practice Guide would result in unreasonable additional expense or delay progress. In such an event the decision must be recorded and the non-compliant item(s) must be audited and details passed to Transport Scotland for future attention.

### **3.7 Good Practice Guide Departures from Standard**

Any design feature that does not comply with the standards set out in this Good Practice Guide is to be treated as a Departure from Standard. Applications for Departures must be submitted to the relevant Transport Scotland Project Manager together with supporting documentation including the mandatory Test of Reasonableness. The determination of the Departure will be the responsibility of a Chartered Engineer within the relevant Transport Scotland internal project management team, with relevant details recorded as potential barriers to access for future consideration. A copy of the determination must be passed to Standards Branch.

### **3.8 Accessibility Review**

As designs progress, plans should be reviewed to identify any design deficiencies and ensure opportunities to achieve accessible design are properly considered. The assessment and review process detailed in HD 42/17 (DMRB 5.2.5) includes for consideration of the needs of mobility impaired and vulnerable users and shall be applied on all trunk road schemes, this supersedes the accessibility audit process in earlier versions of this guide.

# 4

## DESIGN STANDARDS

### 4.1 Road Link Features

#### 4.1.1 Introduction

This section describes the key inclusive design elements in the design of road link features.

#### 4.1.2 Lay-bys

TD 69/07 (DMRB 6.3.3) sets out the design of lay-bys. Transport Scotland requires the following enhancements to make lay-bys accessible to disabled people.

#### 4.1.3 Parking Lay-bys (Type A)

For Type A lay-bys, a dropped kerb is required to provide access to the footway at the rear of the lay-by to assist people with mobility impairments. An accessible parking bay is to be provided at the exit end of the lay-by.

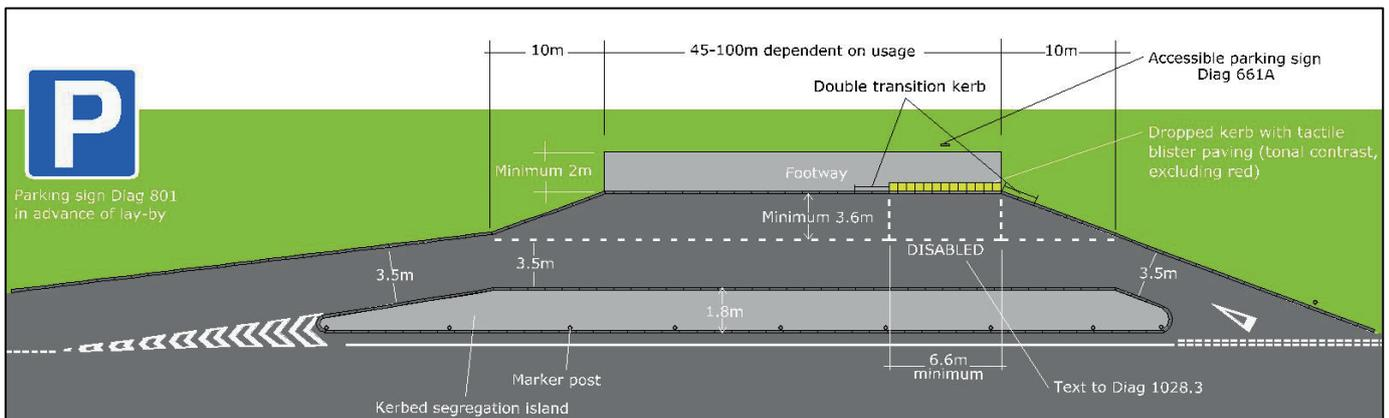
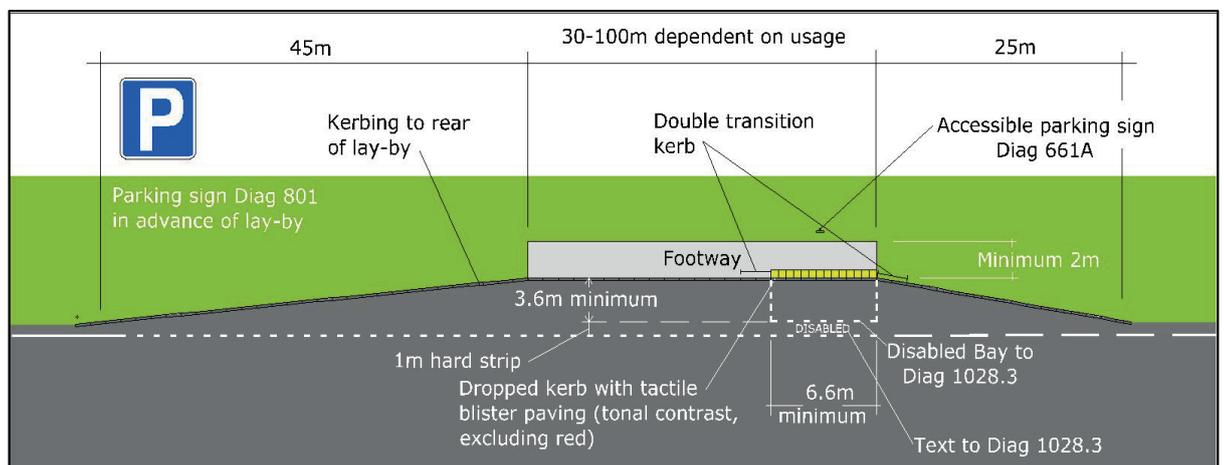

Figure I: Type A lay-by

#### 4.1.4 Parking Lay-bys (Type B)

For Type B lay-bys, a dropped kerb is required to provide access to the footway at the rear of the lay-by to assist people with mobility impairments. An accessible parking bay is to be provided at the exit end of the lay-by.



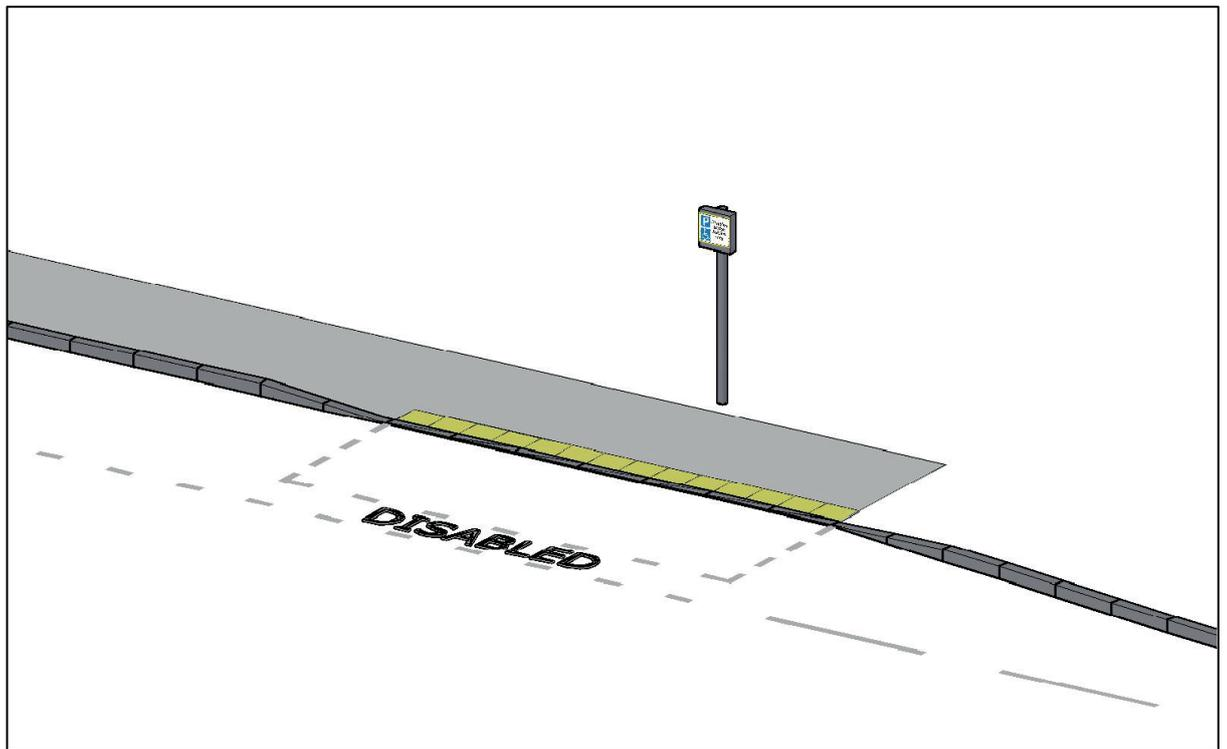
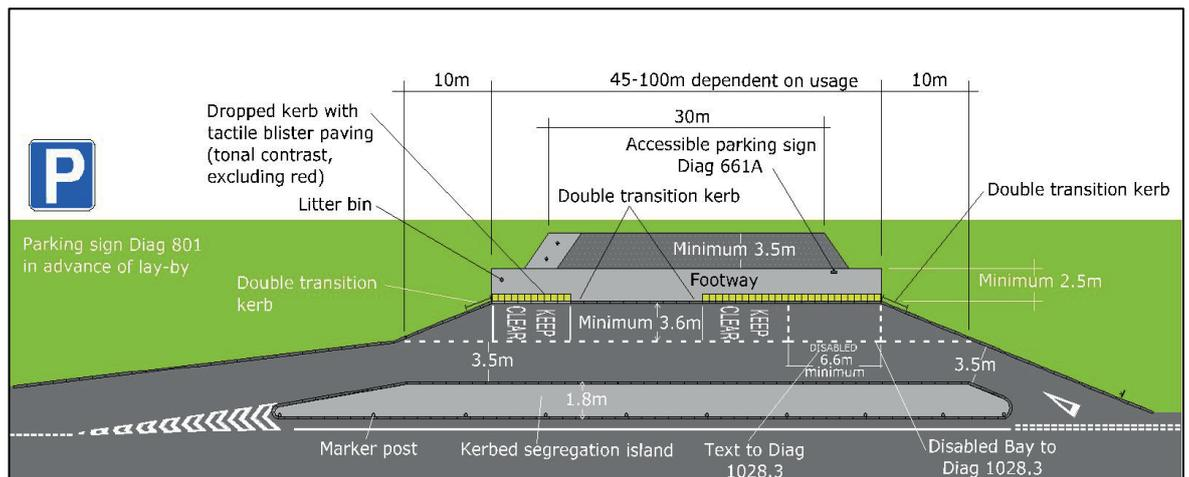

Figure 2 a & b: Type B lay-by

4.1.5 Parking Lay-bys (Type A Lay-by with Trading Facility)

For Type A lay-bys with a trading facility a dropped kerb is required to provide access to the footway at the rear of the lay-by to assist people with mobility impairments. An accessible parking bay is to be provided at the exit of the lay-by, after the exit “keep clear” zone required for trading vehicular access.



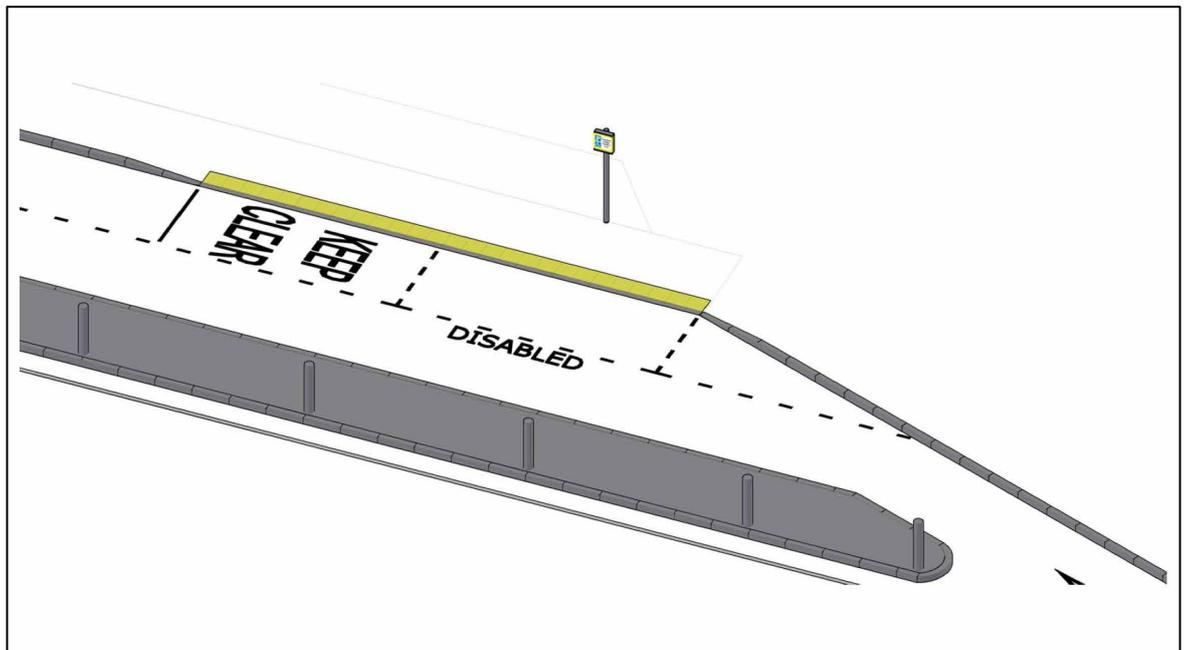

Figure 3 a & b: Type A lay-by with trading facility

#### 4.1.6 Bus Lay-bys

For bus lay-bys, raised bus boarding areas and shelters are to be provided in accordance with the guidance in 'Inclusive Mobility'.

A drop off point should be provided in bus lay-bys in rural areas where no other drop off facility or connecting footway is available. The drop off point should be placed at the exit of the lay-by and include a dropped kerb, but no marked parking bay.

Appropriate access to and from the bus stop should be provided. Opposing bus lay-bys, linked by a suitable crossing facility where feasible, shall be applied on a right-left stagger.

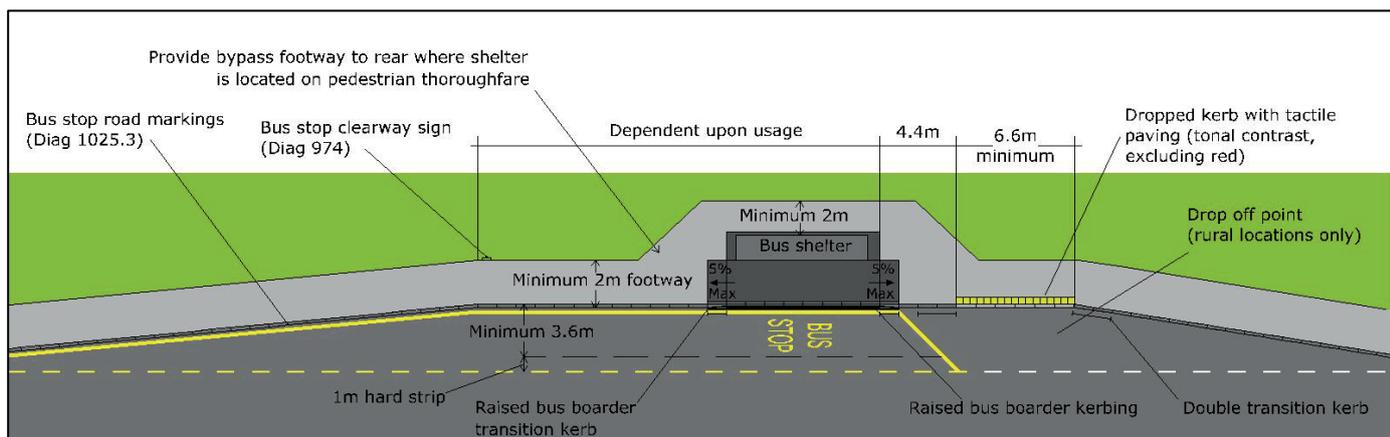

Figure 4: Bus lay-by

#### 4.1.7 Bus Stops (In-line)

Bus shelters are to be designed in accordance with 'Inclusive Mobility'. Designers are to provide for current bus sizes and manoeuvrability. It is recognised that bus dimensions may change in the future, therefore some extra space should be allowed.

This is particularly relevant where the bus stop is located adjacent to marked parking or loading bays.

Within lit urban areas restricted to 30 miles per hour or less bus stops may be built out from the footway to allow buses to pull up parallel with the kerb and resume travel without requiring to wait for a gap in passing traffic. The buildout should be sited such that the bus shelter and waiting passengers do not obstruct passing pedestrian flows. Bus passengers and bus drivers must have an unobstructed view of one another. A raised bus boarder is to be provided.

Appropriate access to and from bus stops should be provided. Opposing bus stops, linked by a suitable crossing facility, shall be applied on a right-left stagger.

For roads with a speed limit of  $\leq 40$  miles per hour, raised bus boarding areas are to be provided in accordance with the guidance in 'Inclusive Mobility'. On roads with a speed limit of  $> 40$  miles per hour bus stops are to be located within a lay-by, with raised bus boarders. Where an in-line stop already exists raised bus boarders are not to be used on roads with a speed limit  $> 40$  miles per hour.

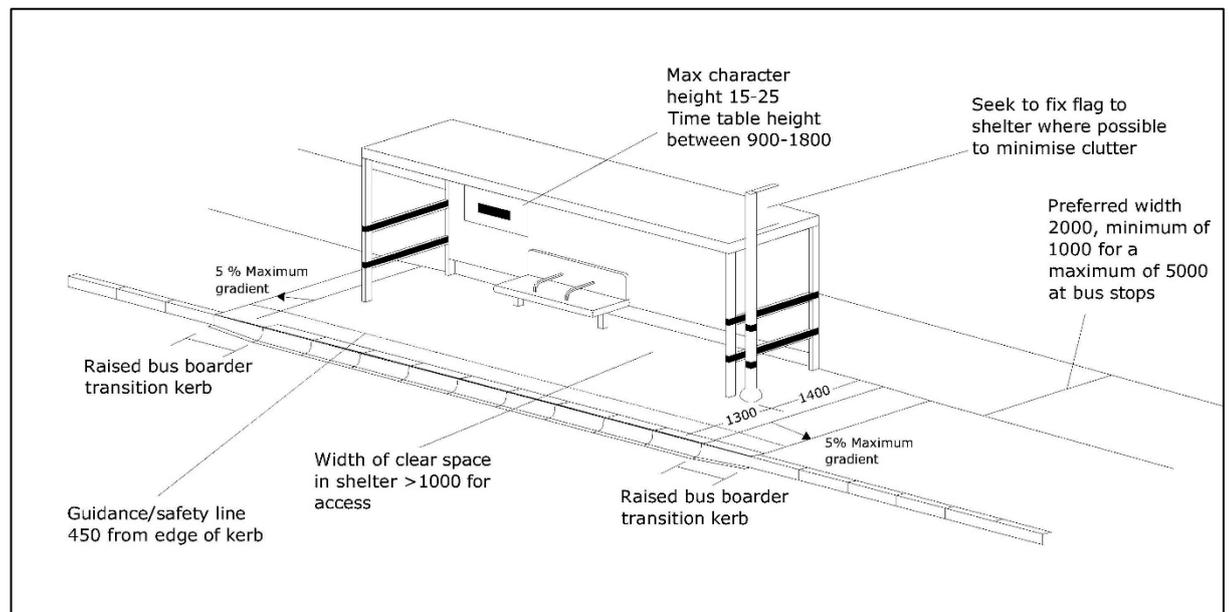

Figure 5: Standard footway and bus stop

#### 4.1.8 Controlled Pedestrian Crossings

TA 68/96 (DMRB 8.5.1) covers the design of pedestrian crossings. Signal controlled pedestrian crossings are required by disabled people to cross busy roads. This is particularly the case for visually impaired people. Red coloured tactile paving must be provided to help visually impaired people to find controlled crossing points. Illumination levels on pedestrian crossings should also be carefully considered.

When providing controlled pedestrian crossings, audible signals and tactile indicators (rotating knurled cones for example) are to be provided, in addition to visual signals. These features are also to be provided at pedestrian facilities at signalised junctions. It may not always be practical to provide audible signals, such as where two crossings are close together, but tactile indicators must always be provided. The technology used in puffin crossings has a number of advantages for pedestrians over the older pelican type crossing including on-crossing detection which senses when pedestrians are using the

crossing and extends the green time for pedestrians and holds the signals for drivers at red. For these reasons all new controlled crossings with pedestrian facilities shall include the features of puffin crossings further to the guidance in 'Inclusive Mobility' and the 'Puffin Crossing Good Practice Guide' (Department for Transport, 2006). These documents contain detailed advice on the design and publicity of puffin crossings.

Transport Scotland can no longer support the use of zebra crossings because they are unsuitable for visually impaired pedestrians.

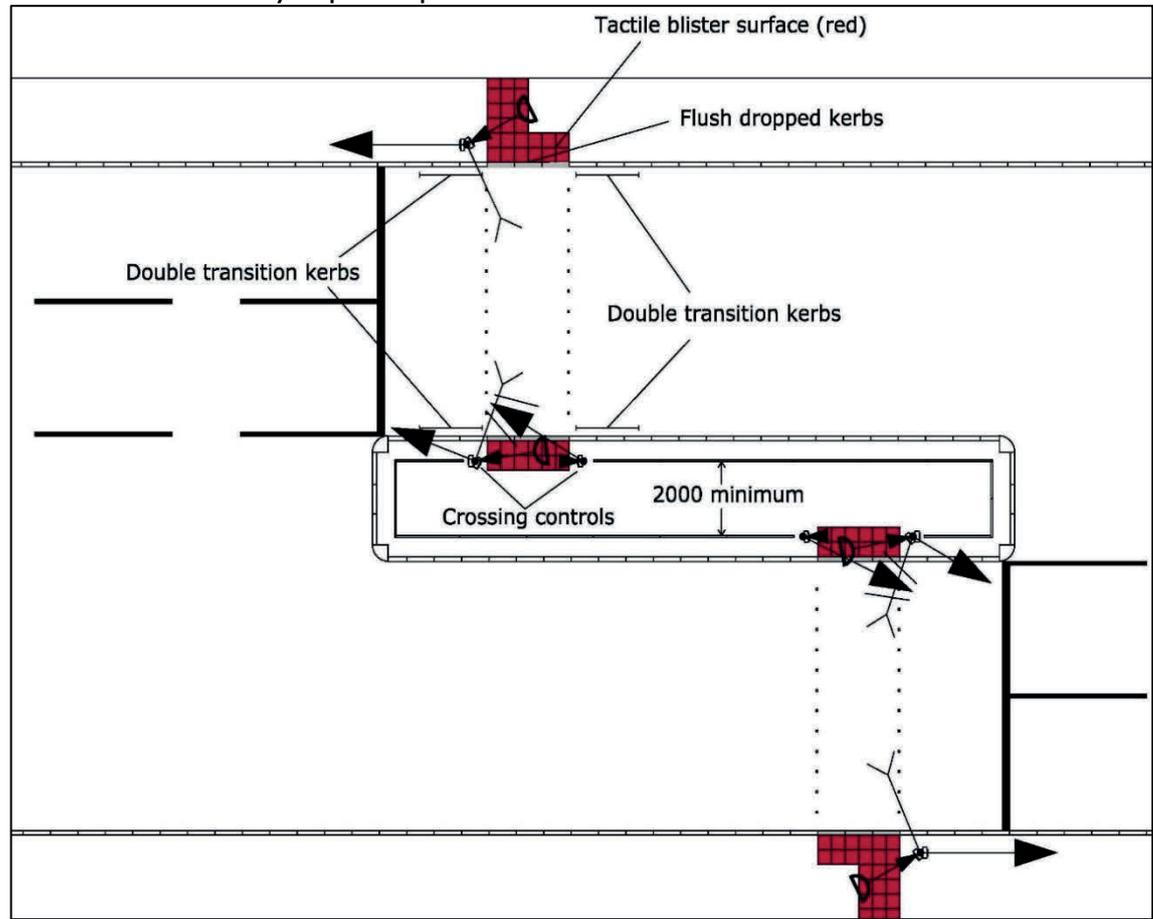

Figure 6: Controlled pedestrian crossing

#### 4.1.9 Dropped Kerbs

Dropped kerbs must be used at all pedestrian crossings (controlled or uncontrolled).

All new crossing installations must be flush with the adjacent road surface, the permissible tolerance being 0 to 6 millimetres.

The following dropped kerb issues are particularly important:

- The upstand at most dropped kerbs is higher than the 6 millimetres tolerance, thus creating a significant barrier to access;
- When retrofitting a dropped crossing into an existing footway where the installation of a flush dropped kerb has the potential to create an area of standing water, additional gullies may be required;
- The use of single transition kerbs at crossings is common practice but this results in most footways exceeding maximum recommended gradients. 'Inclusive Mobility' deals with design of footways and states the maximum gradient should be 8 per

cent (1 in 12) in such circumstances. All dropped kerbs at crossing installations are to be dropped over two transition kerb lengths to achieve the required approach gradients unless the layout of the crossing provides an alternative way of achieving this.

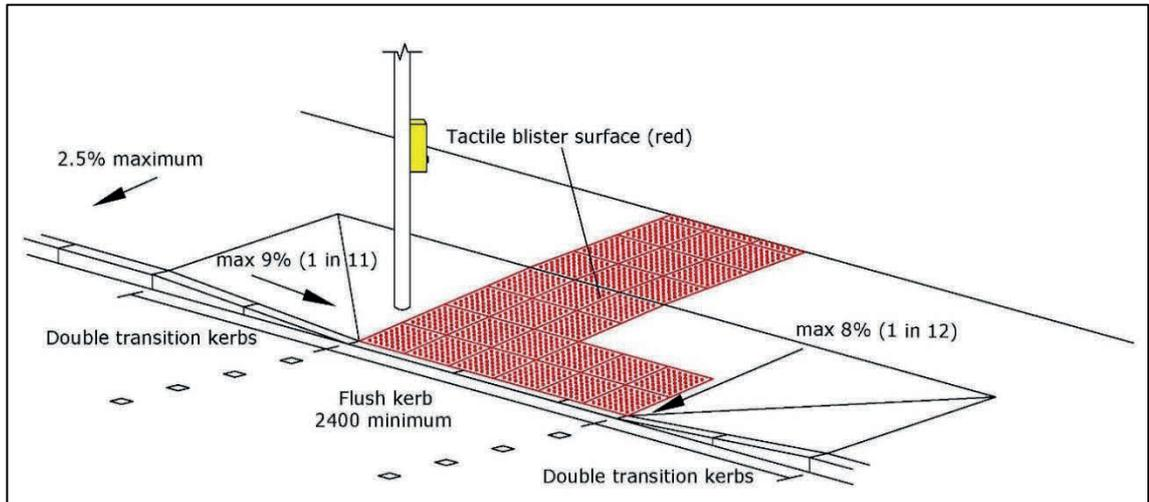

Figure 7 a: Flush dropped kerb (inset controlled crossing)

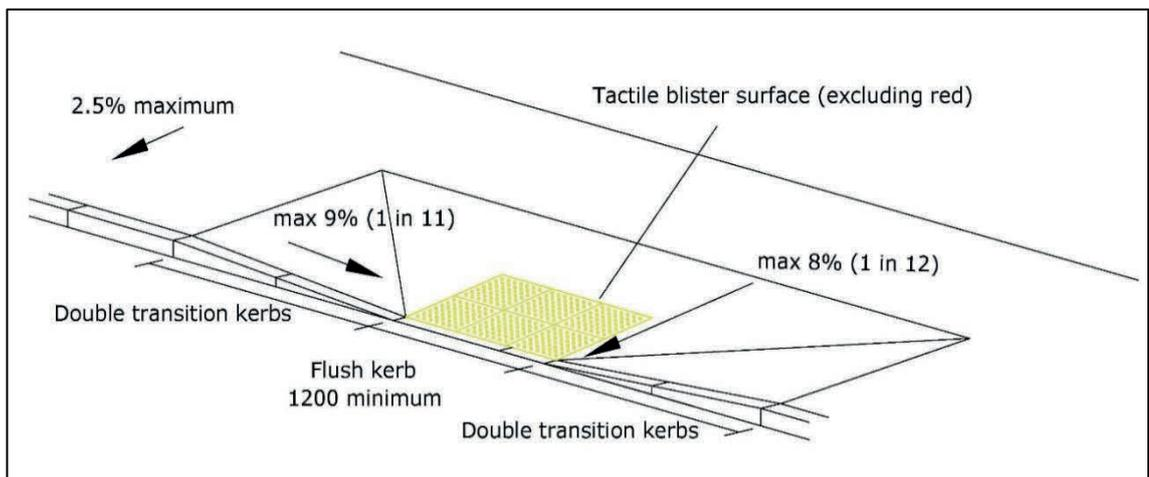

Figure 7b: Flush dropped kerb (uncontrolled crossing away from a junction)

#### 4.1.10 Footway Width

The minimum width of a footway is to be 2000 millimetres in normal circumstances, since this width allows two wheelchair users to pass.

In existing constrained environments and where obstacles are unavoidable, an absolute minimum width of 1500 millimetres may be used without the requirement of a Departure from Standard.

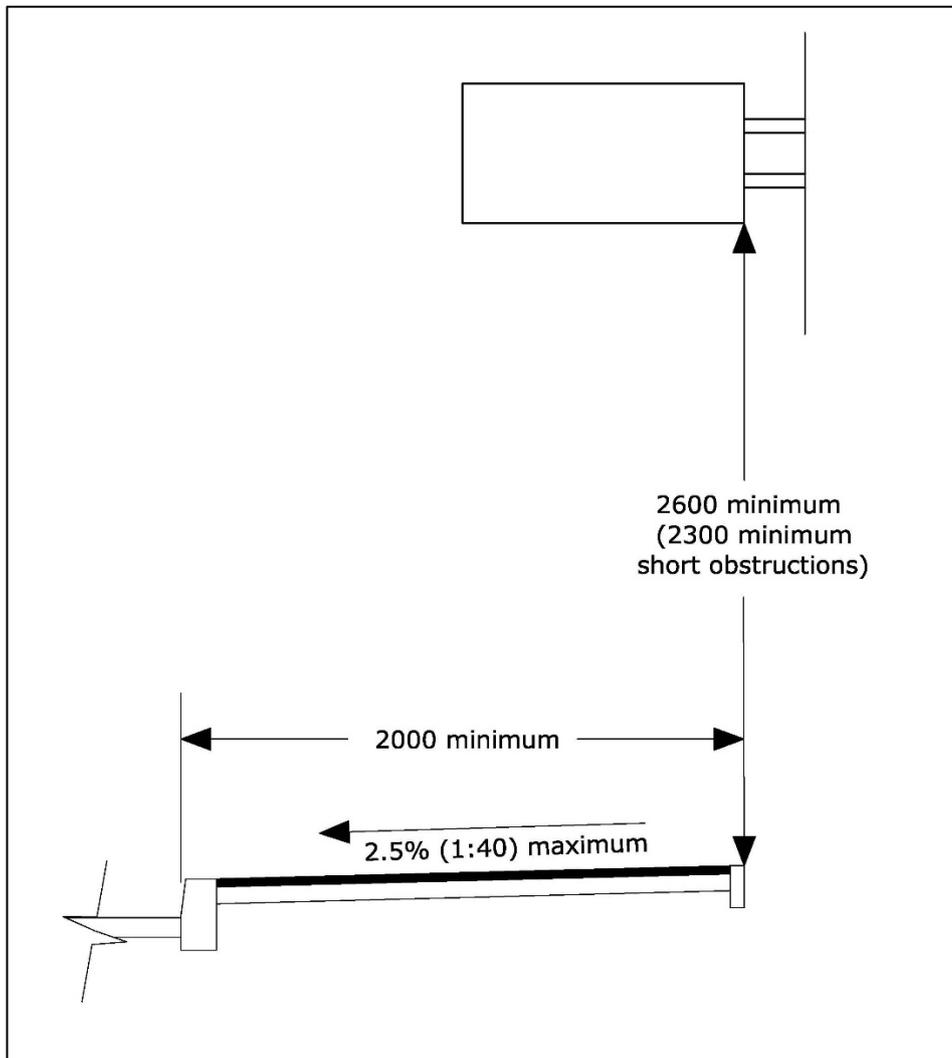

Figure 8: Footway dimensions

#### 4.1.11 Headroom

TD 36/93 (DMRB 6.3.1) sets a minimum headroom of 2600 millimetres, and 2300 millimetres for short obstructions. Trees and bushes close to or overhanging a footway should be cut further back to allow for growth.

#### 4.1.12 Crossfall

Steep cross-falls are problematic for wheelchair users and where the footway falls towards the road this can be potentially dangerous. The maximum crossfall on a footway is to be 2.5 per cent (1 in 40).

#### Longitudinal Gradients

It is generally recognised by all guidance on this subject that steep gradients pose problems for people with mobility impairments, including wheelchair users. Steeper gradients require more effort to ascend and more care to descend.

'Inclusive Mobility' recommends a maximum gradient of 5 per cent (1 in 20). This concurs with the advice in HD 39/16 (DMRB 7.2.5) and most other guidance on the subject.

TD 36/93 (DMRB 6.3.1) deals with underpasses for pedestrians and cyclists, however, longitudinal gradients here should also be a maximum of 5 per cent (1 in 20).

Gradients above the maximum 5 per cent are to be designed as ramps, as described in Section 4.3.

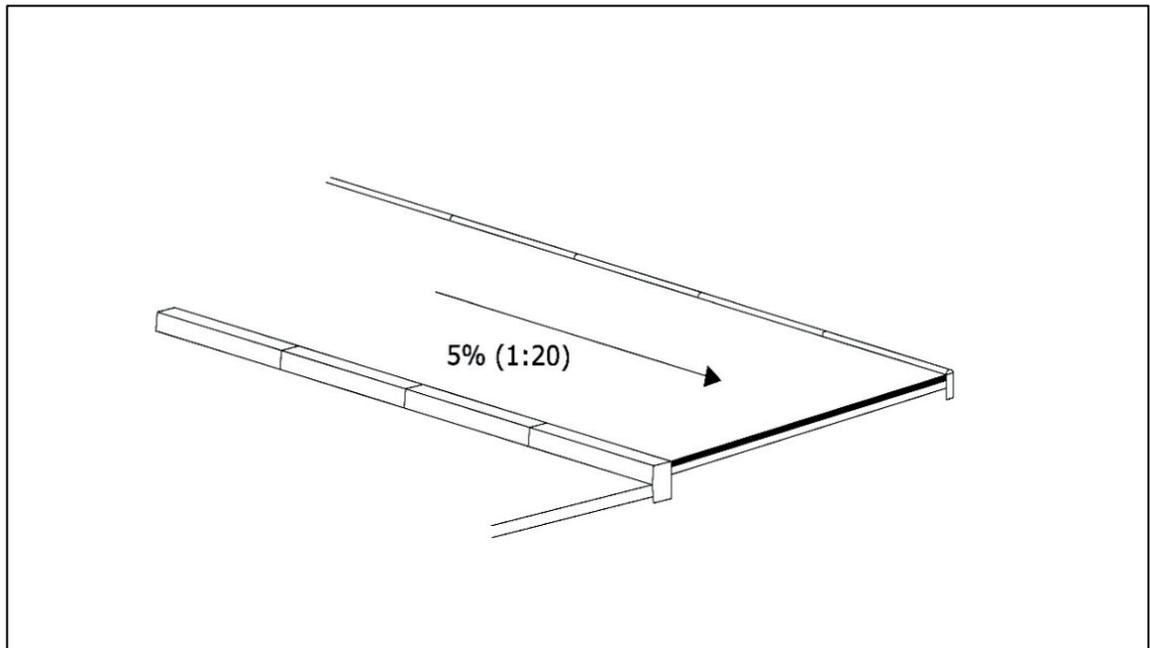

Figure 9: Maximum longitudinal gradient

#### 4.1.13 Landings (Rest Points)

The steeper the gradient the shorter the length of slope that people with mobility impairments can negotiate with ease. Level landings on a route with gradients allow people to rest comfortably and safely.

A gradient of 5 per cent (1 in 20) or greater must be considered as a ramp, which requires level landings at regular intervals (the steeper the ramp the shorter the distance between landings). Handrails must be provided on both sides. For the design of steps and ramps, refer to Section 4.3.

The Scottish building regulations acknowledge that gradients of between 2 per cent (1 in 50) and 5 per cent (1 in 20) can pose a barrier to some people with mobility impairments. There is a requirement within the regulations that level rest points must be provided at intervals proportional to the gradient on the approach to a building entrance with a maximum rise of 500 millimetres between rest points.

Level rest points should be provided on footways with gradients between 2 and 5 per cent.

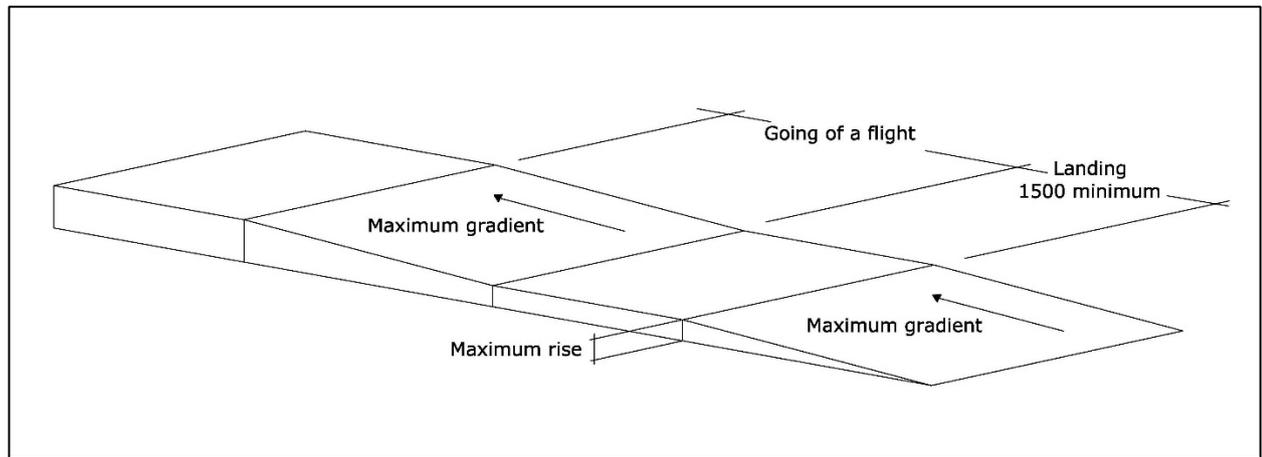

Figure 10: Landings

#### 4.1.14 Shared Pedestrian/Cycle Routes

'Cycling by Design' (Scottish Government, 2011) describes the design of shared pedestrian/cycle routes. It is acknowledged that there can be conflict between different user groups and shared use facilities should be restricted to where the flows of cyclists or pedestrians are low.

Research by Guide Dogs and the Royal National Institute for the Blind identifies shared surfaces as posing a threat to vulnerable road users, including those with physical, sensory or cognitive impairments.

As a guide, the use of shared pedestrian/cycle routes are not recommended in congested urban environments where pedestrian and cycle use is high. However, the decision to provide a shared facility should always involve considering the views of the local Access Panel and groups representing visually impaired people.

#### 4.1.15 Surfacing Materials

Both HD 39/16 and 'Inclusive Mobility' concur on the need for smooth, slip resistant footway surfaces. There is also agreement on what types of surfaces achieve this aim: these include concrete flags and pavements. HD 39/16 describes ways of ensuring the long-term integrity of footways, such as avoiding damage by tree roots and locating services under the verge rather than the footway where possible. The slip resistance of the footway surface must meet the requirements of HD 39/16.

## 4.2 Junctions

### 4.2.1 Introduction

This section describes the key inclusive design elements in the design of junctions.

### 4.2.2 Signalised Junctions

TD 50/04 (DMRB 6.2.3) provides guidance on roads users' specific requirements when signal control is being considered. The extent of pedestrian crossing movements, cyclist, equestrian usage, and bus movements should be determined and the provision of specific measures included unless site specific considerations dictate otherwise.

The following are to be provided as a minimum at all signalised junctions:

- TD 50/04 refers to 'Guidance on the Use of Tactile Paving Surfaces' (Department for Transport, 2005) for different types of pedestrian crossing points;

- TD 50/04 states that where pedestrians are expected to cross arms of a junction, tactile surfaces and dropped kerbs shall be provided – this is a mandatory requirement of the DMRB;
- TD 50/04 states tactile paving, tactile rotating cones, audible signals, and dropped kerbs are all mobility aids designed to assist disabled people at the crossing.

The features of puffin type crossings described in Section 4.1.8 are also to be provided at pedestrian facilities at signalised junctions.

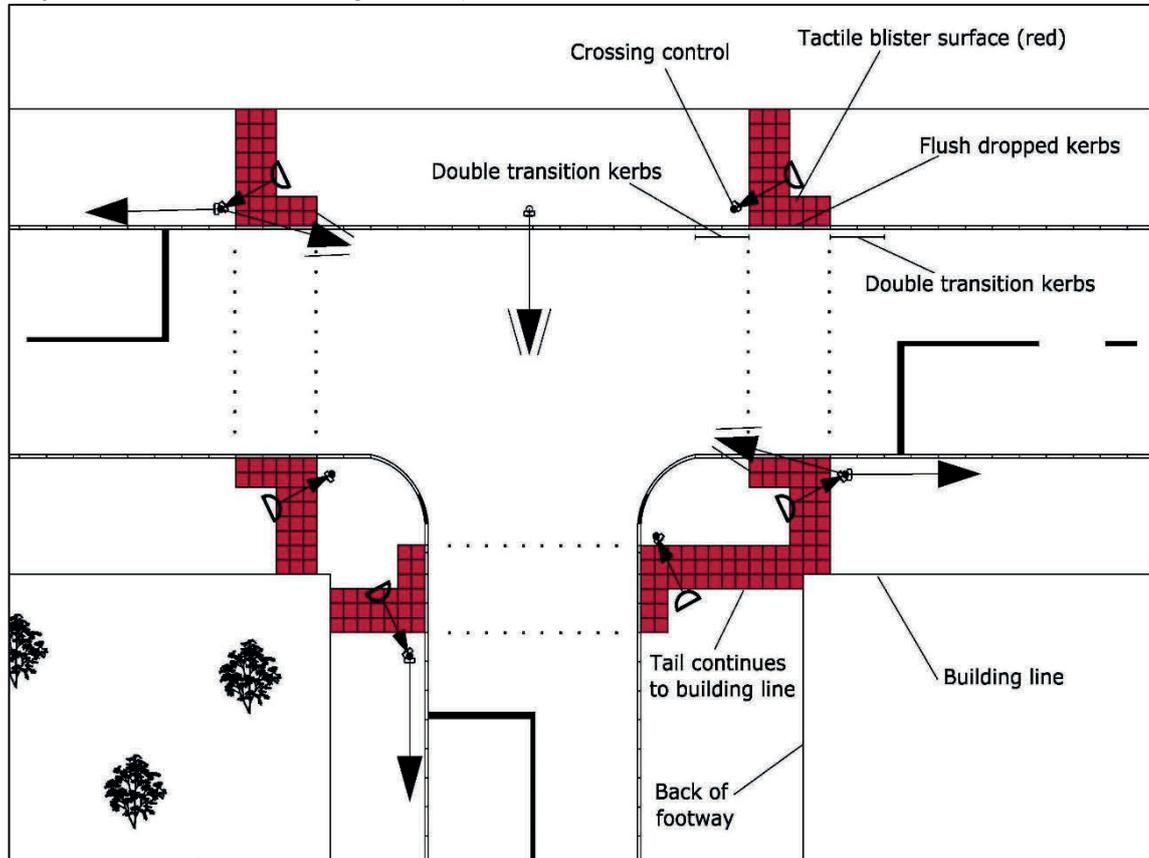

Figure 11: Signalised junction

#### 4.2.3 Major/Minor Priority Junctions

TD 42/95 (DMRB 6.2.6) provides guidance on roads users' specific requirements in designing major/minor priority junctions. The high speed nature of rural roads is such that specific facilities may be required at some locations in order to ensure the safe passage of specific road users through the junction. This is equally true at some urban sites where the junctions may be used intensively by all types of road user.

The following should be provided as a minimum at all major/minor priority junctions where pedestrian movements are expected.

##### Desirable Crossing Arrangement

TD 42/95 highlights that at-grade pedestrian crossing points on the minor road should be a minimum of 15 metres back from the "give way" line, and should be sited so as to reduce to a minimum the width to be crossed by pedestrians provided they do not involve excessive detours from their desired paths. Central refuges are to be used but not on major roads in a rural situation. Where pedestrians cross the minor arm of a junction, tactile surfaces and dropped kerbs are to be provided. Refuges are to be at least 1500 millimetres wide to protect wheelchair users and parents with push chairs

when crossing the road. Tactile surfaces and dropped kerbs are to be provided on refuges. Where a traffic separation island is used as a crossing point by pedestrians it must also be equipped with dropped kerbs and tactile surfaces.

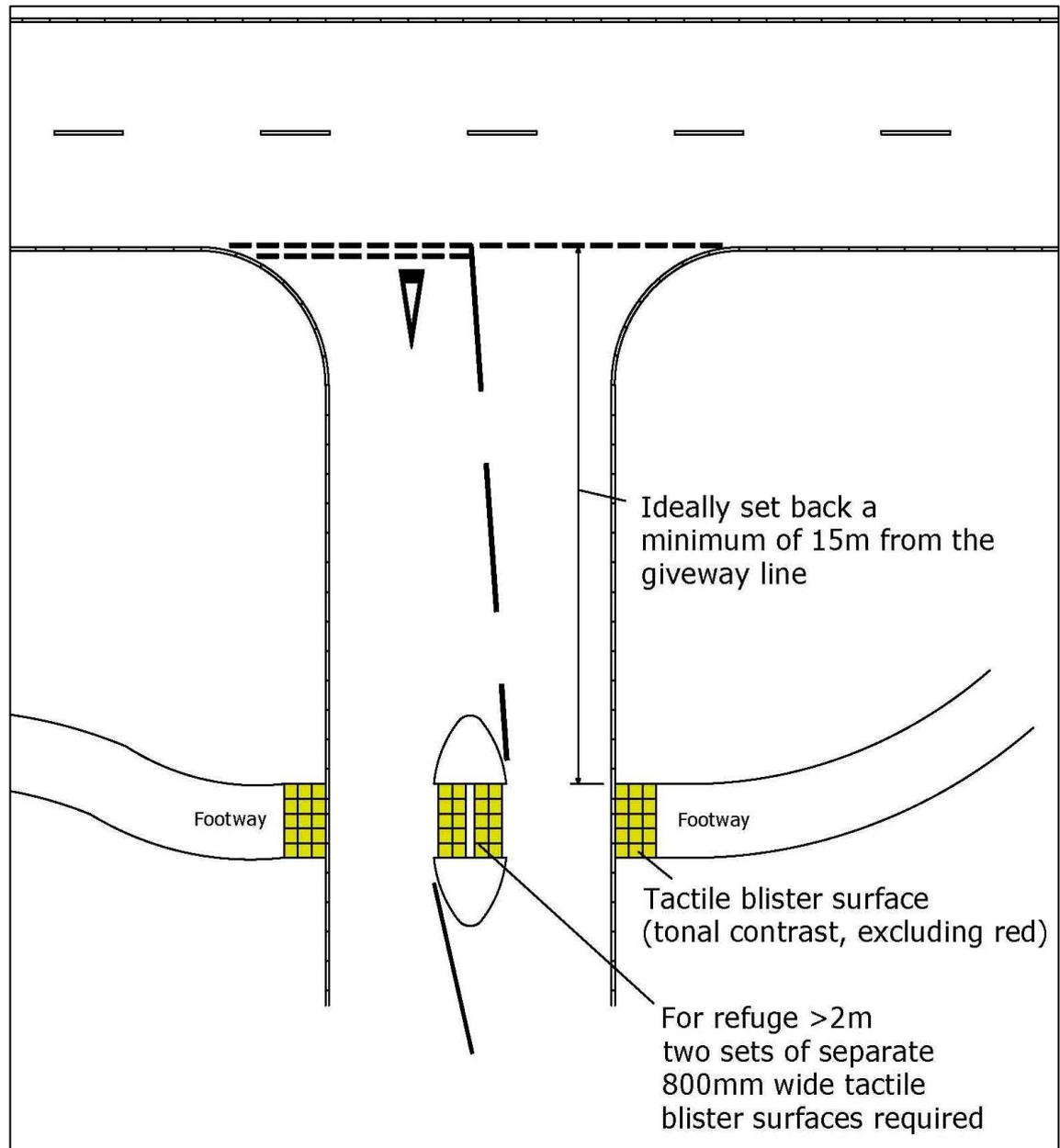

Figure 12: Desirable crossing arrangement

Practical Crossing Arrangement

TD 42/95 highlights that the requirements of pedestrians should be carefully considered in the design and choice of major/minor priority junctions. Although it is preferable to provide separate pedestrian routes away from the junction, as described above, this is rarely practical, particularly in the urban environment.

In such cases, uncontrolled crossings are to be provided on the pedestrian desire line across the minor arm of a junction with the appropriate use of tactile blister paving, dropped kerbs, and a central refuge on the minor road.

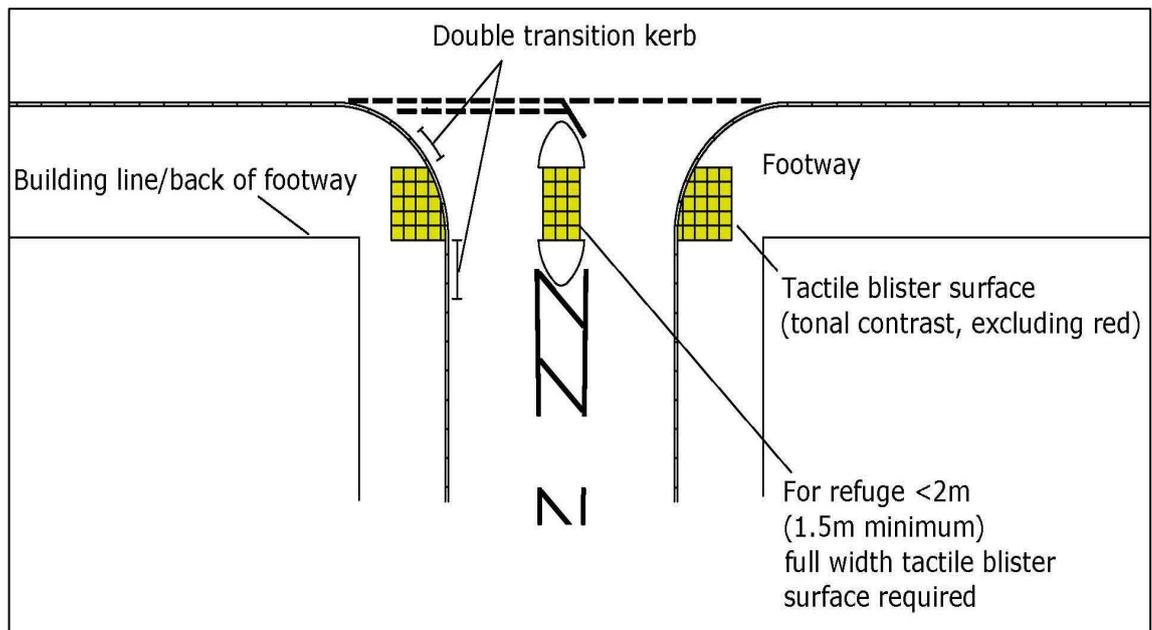

Figure 13: Practical crossing arrangement

#### Alternative Crossing Facilities at Major/Minor Priority Junctions

The following alternative facilities should also be considered for higher trafficked situations:

Displaced controlled pedestrian crossing;  
Subway or footbridge.

#### 4.2.4 Roundabouts

TD 16/07 (DMRB 6.2.3) highlights roads user specific requirements in relation to roundabout design. Separate pedestrian routes with crossings away from the flared entries to roundabouts are preferable where road widths are less and traffic movements are more predictable. Roundabouts feature continuous flows and can be particularly difficult for pedestrians to negotiate, particularly those with mobility impairments. For this reason, uncontrolled crossings at roundabouts are not recommended and an alternative crossing facility should be considered.

#### Alternative Crossing Facilities at Roundabouts

The following facilities should be considered at roundabouts:

Displaced controlled pedestrian crossing;  
Signalisation of the roundabout, with pedestrian facilities;  
Subway or footbridge.

#### 4.2.5 Vehicle Access to the Road (Vehicle Footway Crossovers)

##### Vehicle Footway Crossovers – Domestic

At lightly trafficked footway crossovers, such as where the access to a domestic driveway crosses a footway, a minimum 25 millimetres upstand should be provided between the carriageway and the vehicle crossover.

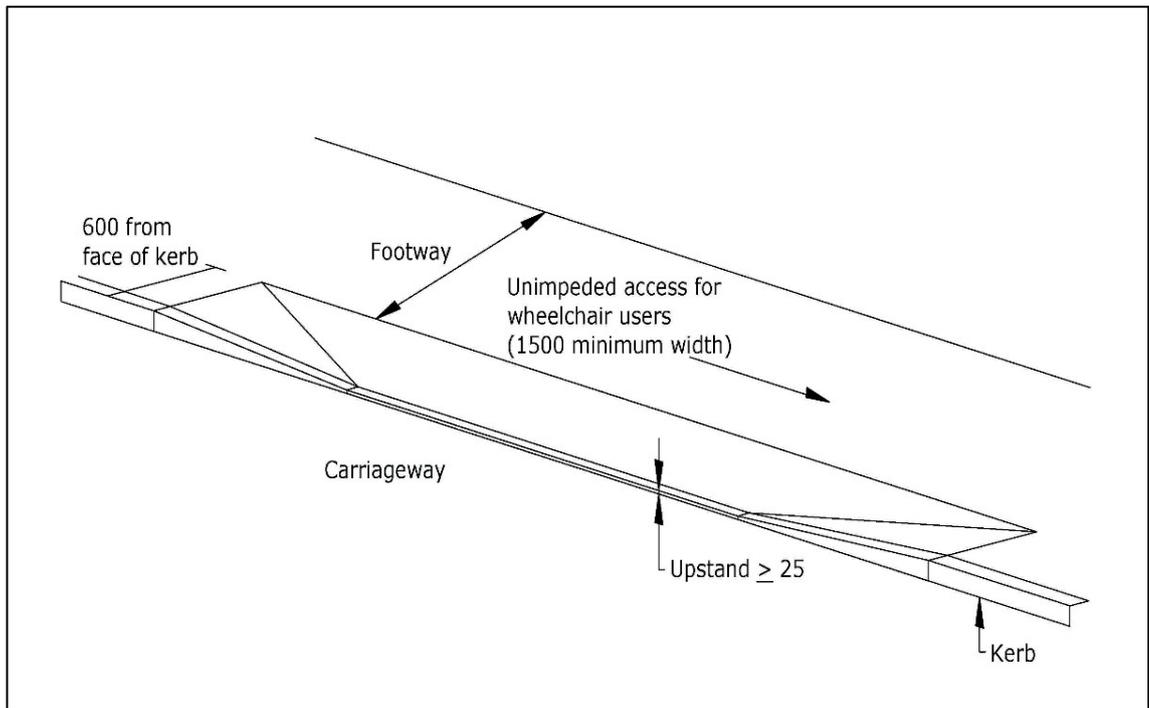

Figure 14: Vehicle footway crossover (domestic)

**Vehicle Footway Crossovers – Commercial**

Where the traffic flow is sufficiently high, a vehicle crossover, or vehicle access should be treated in a similar manner to an uncontrolled crossing at a side road and tactile blister paving should be provided. A traffic calming measure in the form of a ramped table should also be provided within the entrance highlighting to vehicles that this is a footway crossing. In addition to the above, where the crossover surface is being replaced with another surface, it is helpful if the replacement surface provides a contrast in colour and tone with the footway.

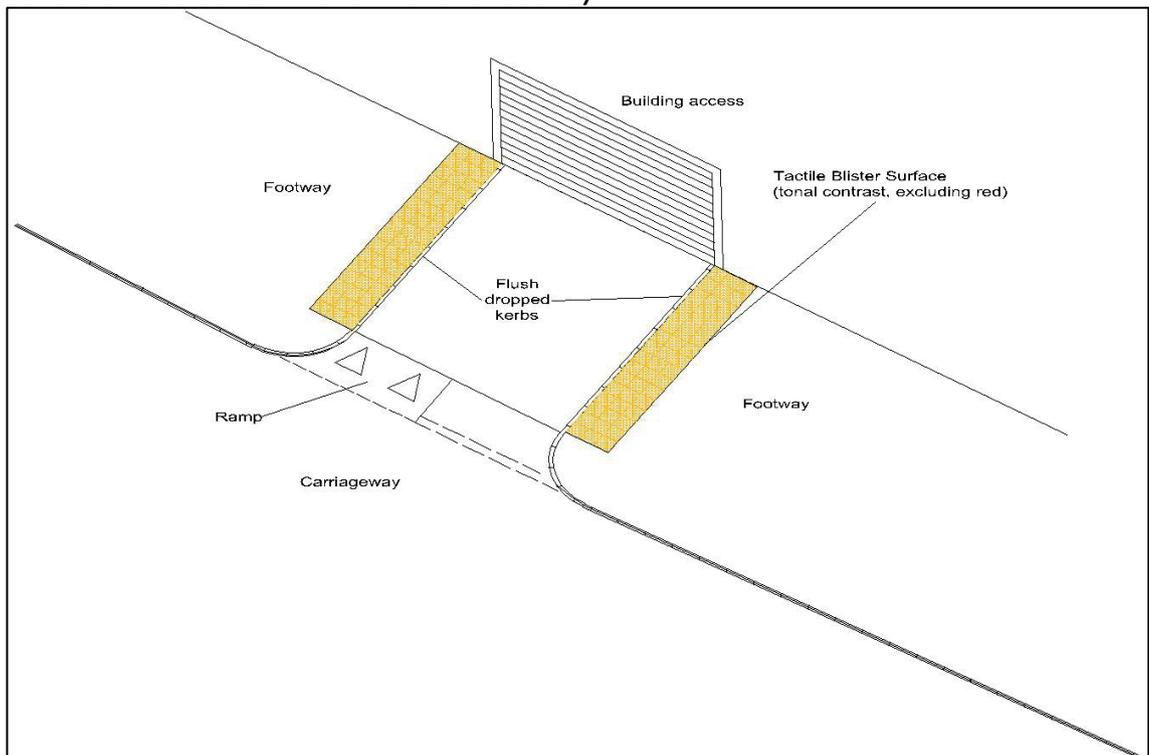

Figure 15: Vehicle footway crossover (light commercial)

## 4.3 Steps and Ramps

### 4.3.1 Introduction

This section describes the key inclusive design elements in the design of steps and ramps which are normally associated with access to bridges and underpasses or when negotiating difficult topography, particularly in the urban environment.

### 4.3.2 Ramps

Gradients of 5 per cent (1 in 20) or greater are to be considered as ramps. The steeper the ramp the shorter the distance should be between landings. Recommended distances between landings for different ramp gradients given in both BS 8300:2009 and 'Inclusive Mobility' are as Table I below (this table may be interpolated):

Gradient	Maximum Length	Maximum Rise
1 in 20 (5 per cent)	10 metres	500 millimetres
1 in 15 (7 per cent)	5 metres	333 millimetres
1 in 12 (8 per cent)	2 metres	166 millimetres
More than 1 in 12 (> 8 per cent)	Not permitted	Not permitted

Table I: Ramp gradients and lengths

Above a certain length, even with the appropriate gradient and number of rest points, a ramp is a barrier to independence for many people with mobility impairments. BS 8300 recommends that no series of ramps should have a rise greater than 2 metres, unless there is an alternative route such as a lift. However, BS 8300 is targeted at buildings and their approaches and it would not be reasonable or practical to provide lifts at a large proportion of locations on the road network. 'Inclusive Mobility' quotes examples of acceptable ramp lengths used in the rail environment. However, the ramps in this environment are normally under cover and there is often assistance available at most railway stations. The BS 8300 standards for ramps set the only dimensions which stand up to scientific scrutiny for self propelled wheelchair users.

Gradients of 1 in 20 (5 per cent) or greater are to be considered as ramps and all ramps must meet the criteria described in 'Inclusive Mobility', which requires level landings (at least 1500 millimetres long) at regular intervals (the steeper the ramp the shorter the distance between landings). Handrails must be provided on both sides. Steps must always be provided as an alternative to a ramp, refer to the following sections on steps for more details.

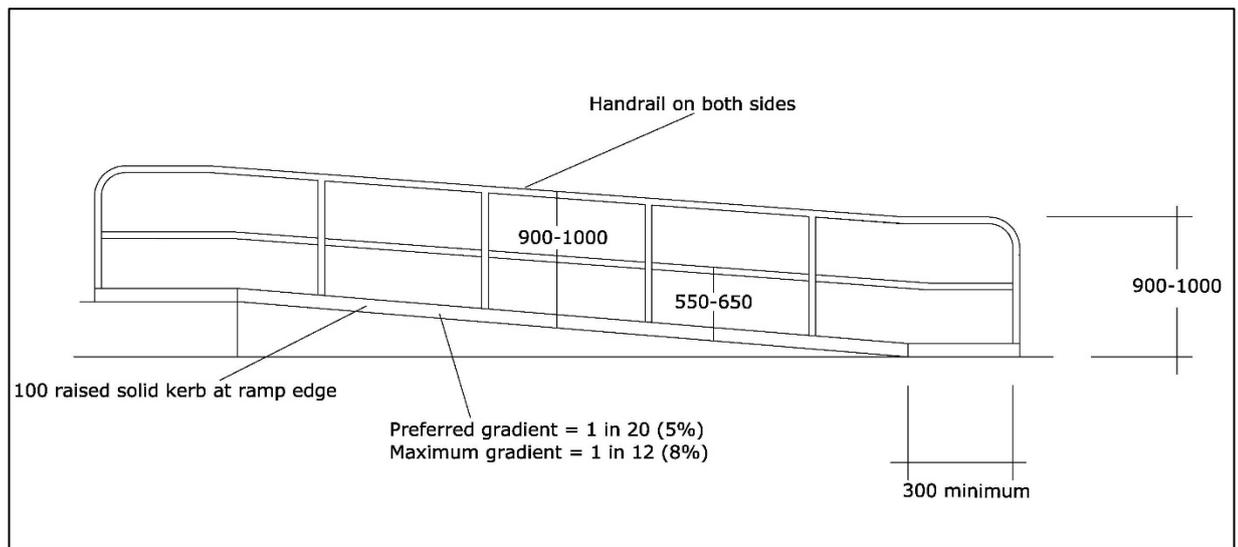

Figure 16: Ramp

#### 4.3.3 Steps – Dimensions

A large proportion of disabled people find it easier and safer to use well designed conventional steps rather than a ramp. It is now well recognised that stepped ramps are a compromise of different requirements and do not work well for anyone; this feature is common on footbridges built in the 1970s and 1980s. BD 29/17 (DMRB 2.2.8) on the design criteria for footbridges recognises the desire to provide steps as an alternative to a ramp. There is a consensus between all the documents including BD 29/17 that open risers are not acceptable. Steps can be a hazard for people with visual impairments, and small numbers of steps can be more difficult to identify than full flights. Corduroy warning surface must be used to warn of a flight of steps and step nosings must be highlighted from the steps and risers.

The maximum number of steps in a flight in normal circumstances should be no more than 12 and the minimum number should be 3 steps. Where the change in level is less than 260mm, a ramp should be provided instead of a single step. The preferred step going is 300 millimetres and the rise should be between 150 millimetres and 170 millimetres. Level landings should be provided between successive flights of steps, at least 1200 millimetres long, preferably 1800 millimetres, and across the full width of the steps.

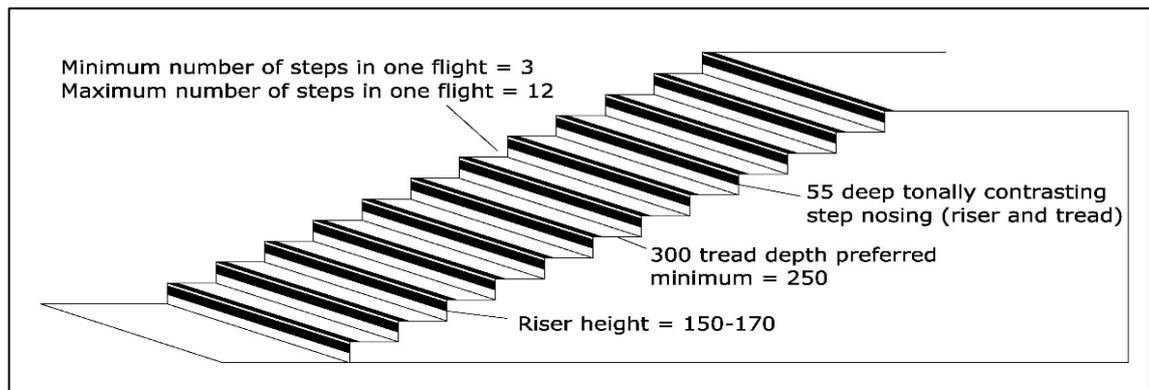

Figure 17: Steps – dimensions

4.3.4 Steps – Tapered Risers

Tapered risers, i.e. where the rise of a step is not parallel to the rise of the step above or below, is especially dangerous for visually impaired people. This feature is ruled out by BD 29/17 and the Scottish building regulations.

4.3.5 Steps – Nosings

'Inclusive Mobility' and other good practice documents recommend step nosings should be highlighted with a 50-60 millimetres deep tonally contrasting strip on both the tread and the riser to ensure this important feature is noticeable when ascending and descending a flight of steps. Light levels are often lower than desirable in the pedestrian environment and step nosings are important features for all pedestrians but especially important for people with visual impairments.

#### 4.3.6 Handrails

'Inclusive Mobility', TD 36/93 and all other guidance documents, including BS 8300 recognise the need for handrails on both sides of ramps and stairs. There is also a consensus on a round or oval gripping profile as being the most appropriate and on the need to extend handrails past the top and bottom of a flight.

Handrails are very important. People with mobility impairments use handrails for support while people with visual impairments use the rails as a guide to where they have reached on a flight. People with mobility impairments often have a weakness on one side of their body and they may use a stick or crutch in one hand. Therefore, they can only grip a rail with the same hand whether ascending or descending. Extending the handrails past the top and bottom of a flight can help to indicate the end of a flight to visually impaired people and also helps people with mobility impairments by allowing them to grip the rail before ascending or descending. Handrails should contrast in tone with their background to assist visually impaired people, and they should be comfortable to grasp in hot or cold weather.

The height of handrails is clearly established in TD 36/93, 'Inclusive Mobility' and the Scottish building regulations. 'Inclusive Mobility' also recommends providing a lower handrail for children and people with reduced stature. This additional rail will be particularly important on routes to primary schools.

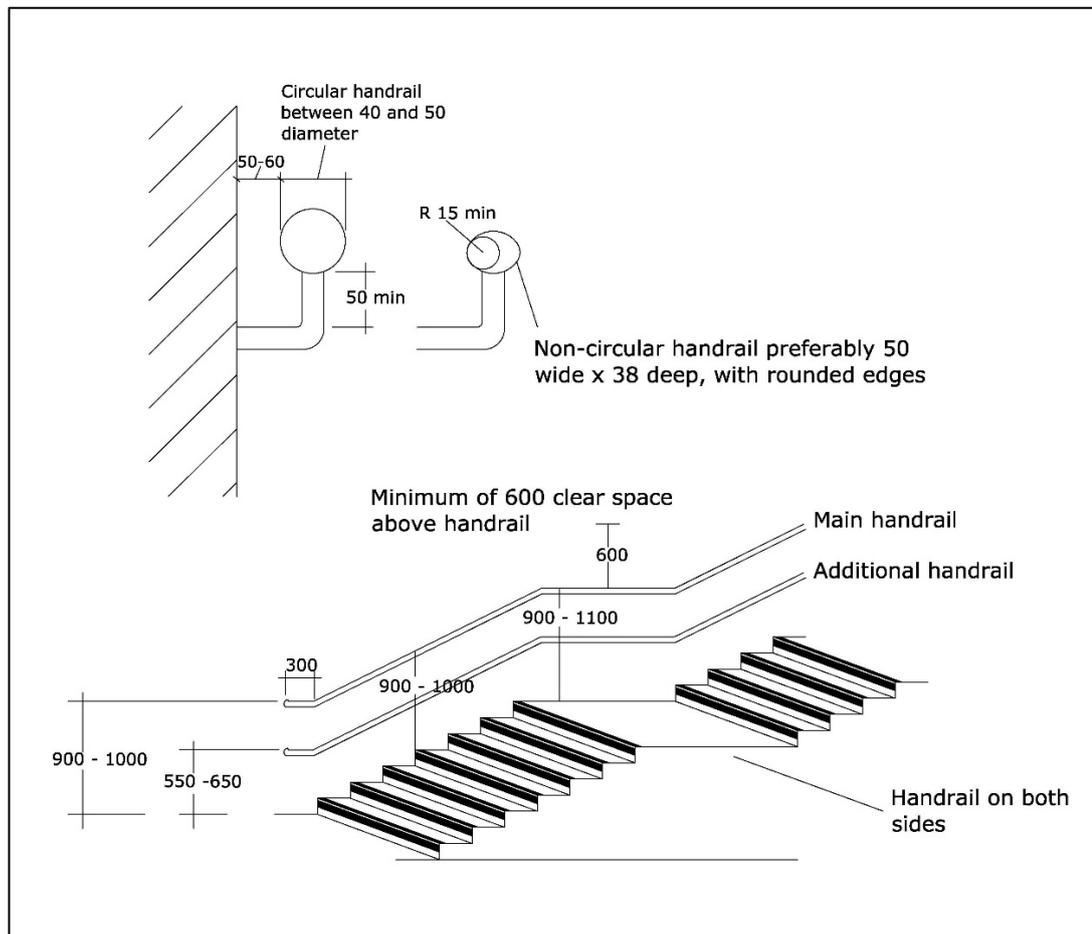

Figure 18: Steps – handrails

## **4.4 Tactile Surfaces**

### **4.4.1 Introduction**

This section describes the design functions of the different types of tactile paving to assist visually impaired pedestrians using the road network.

### **4.4.2 Tactile Surfaces**

There are a variety of different tactile surfaces used in countries across the world to convey information to visually impaired people in the pedestrian environment and the methodologies for using these surfaces vary. In the UK there are six recognised on-street tactile surfaces. These surfaces must be used consistently in order to provide effective warning, way finding and information clues to visually impaired people.

The authoritative source of information on the use of tactile surfaces in the UK is the Department for Transport publication 'Guidance on the Use of Tactile Paving Surfaces'.

The most frequently used tactile surface is blister paving. There is a common misconception that this surface is used to indicate a safe place to cross a road. However, the principal message this surface indicates is that there is a lack of a kerb height change between the road and the footway, for example where the kerb has been dropped flush with the road at a pedestrian crossing. A kerb upstand between the road and the footway is an important marker to visually impaired people, since it delineates between the road and the footway where it is safe to walk. A kerb can also convey the direction the footway is taking – for this reason it is important at dropped kerbs that the tactile paving is orientated in exactly the direction of crossing (tactile paving slabs must therefore be cut where they abut kerbs around the corner radius of a junction – refer to

Figure 13). At controlled crossing points the secondary message that tactile blister paving conveys to visually impaired people is the location of the crossing control pole. It is important that visually impaired people can find and use controlled crossings, since these are the safest place for vulnerable road users to cross the road.

Tactile paving should contrast tonally with the surrounding paving materials. For safety reasons red coloured tactile blister paving is reserved for controlled crossings.

Metal studs have been used to create the blister profile in a number of city centres. These studs have proved to be slippery when wet and must not be used. It is also important to ensure that the top surface of the blister is flattened, as a round surface can be uncomfortable and increases the risk of slipping or tripping.

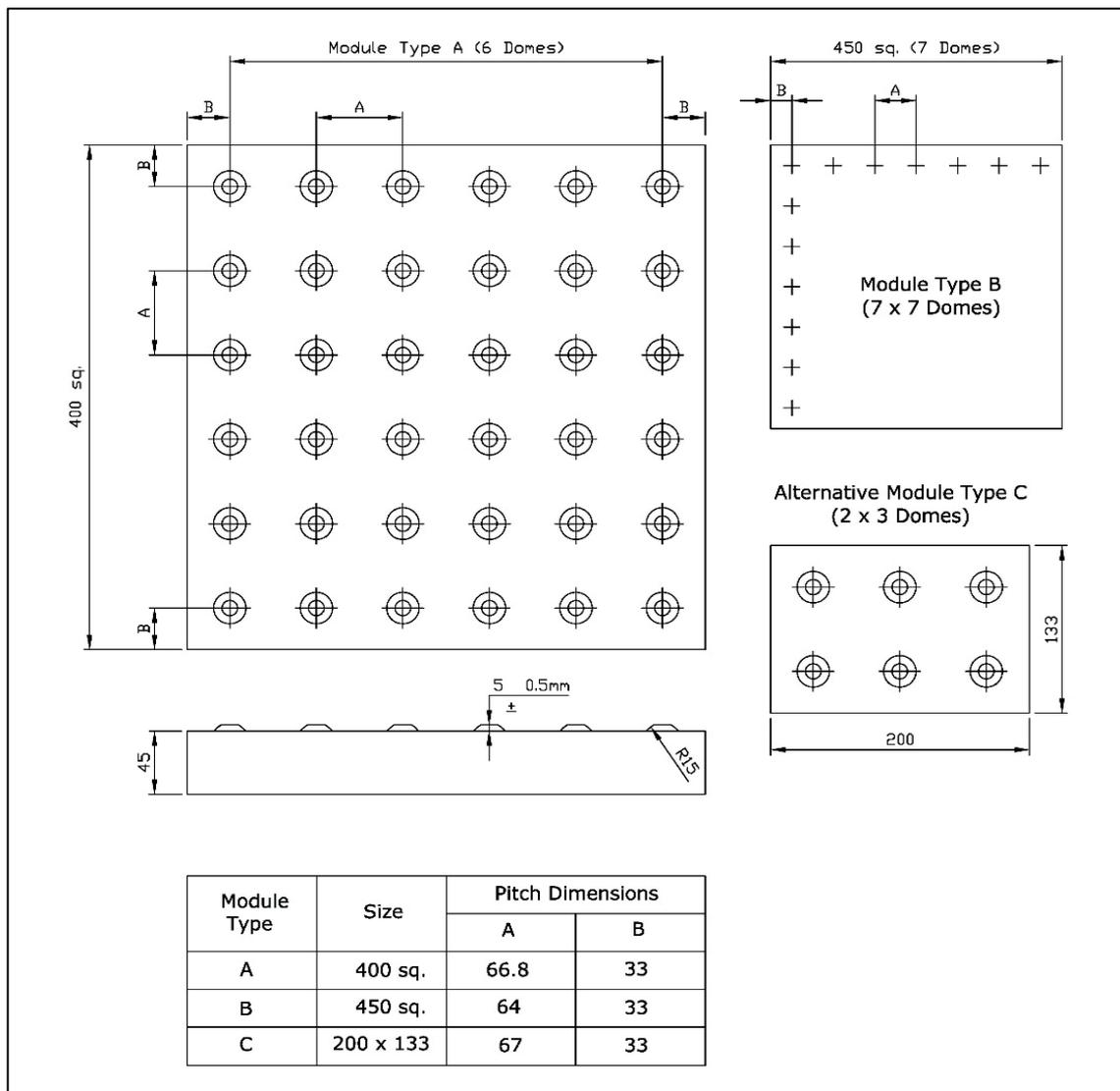

Figure 19: Blister surface

The other five surfaces are as follows. These tactile profiles can be created in a variety of different materials, including concrete, natural stone and rubber, for a variety of situations. The material chosen must have a similar slip resistance to the surrounding paving materials to avoid creating a trip hazard.

- Corduroy tactile warning surfaces – this surface is used to warn visually impaired people in advance of hazards in the pedestrian environment such as steps or junctions with shared pedestrian/cycle routes.

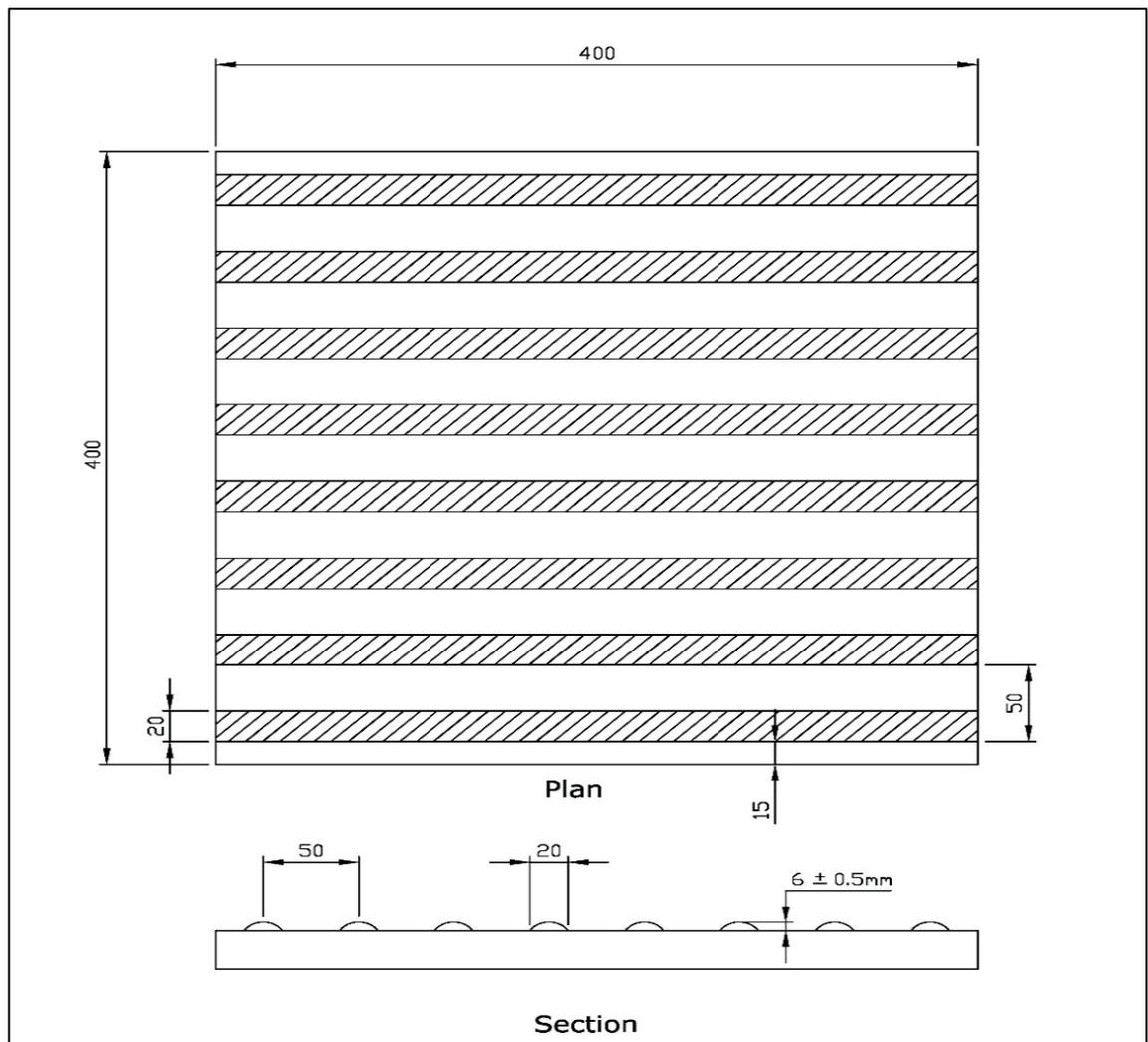

Figure 20: Corduroy hazard warning surface

- Cycletrack surface – this surface is used to delineate between the pedestrian and cyclists sides of a segregated route at salient points along the route.

‘Cycling by Design’ describes the design of shared pedestrian/cycle routes. It acknowledges that there can be conflict between users – refer to Section 4.1.14.

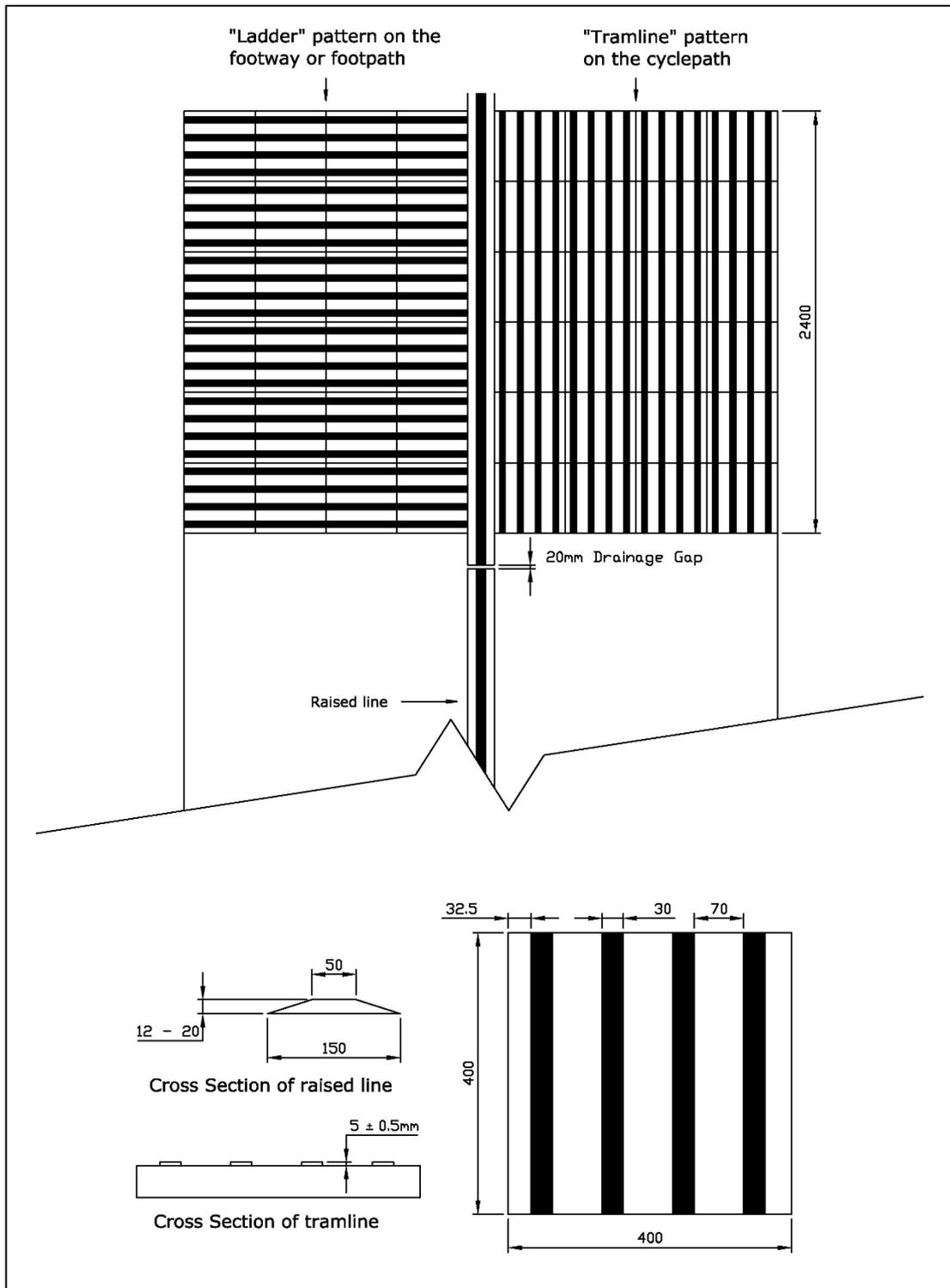

Figure 21: Shared cycletrack/footway surface and central delineator strip

- **Guidance surface** – this flat topped ribbed profile is intended to define a safe route through wide, open pedestrian areas, such as a town square, with few orientation clues for visually impaired people. There should be no need for this surface in new well designed environments, since visual and non-visual orientation clues can be integrated into the design of the public realm. However, Access Panels and organisations representing visually impaired people may identify a need for the use of this surface to mitigate wayfinding problems in an existing environment. Further advice is contained within ‘Designing Streets’ (Scottish Government, 2010).

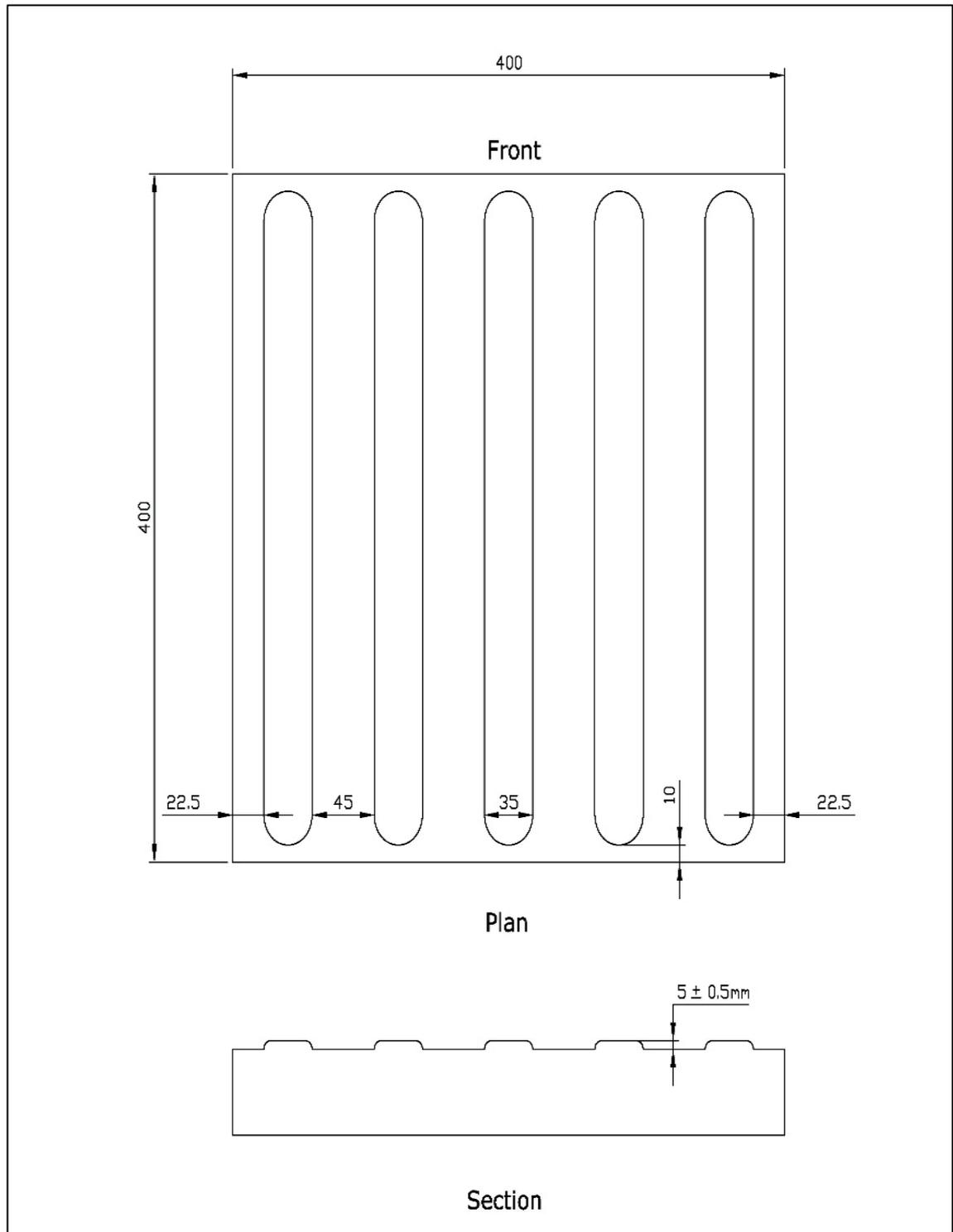

Figure 22: Guidance path surface

- On-street platform edge – this lozenge shaped profile is intended for use on raised on-street tram platforms to orientate visually impaired people and warn of the drop on to the rails.

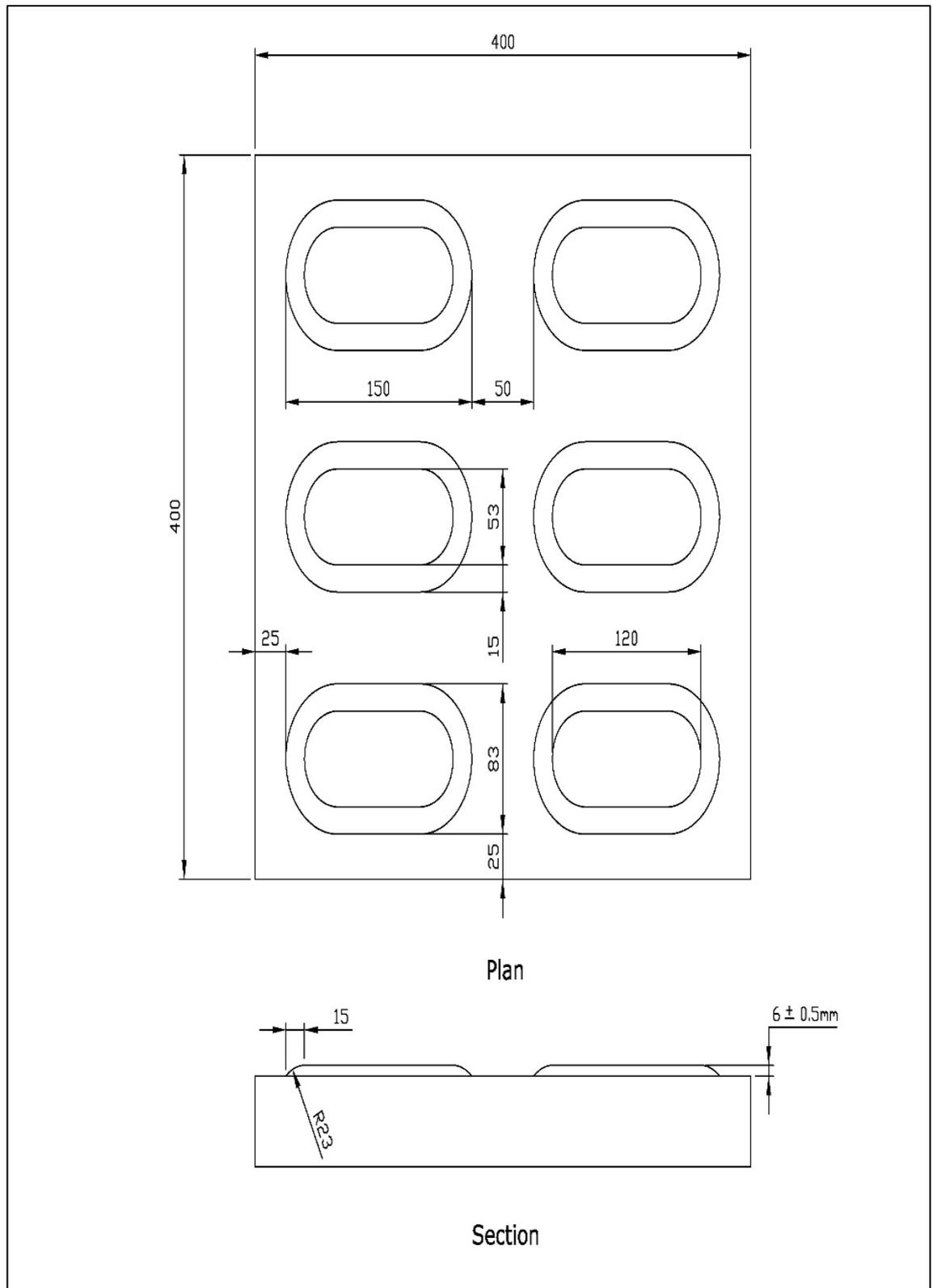

Figure 23: Platform edge (on-street) warning surface

- Information surface – this rubber surface is used to highlight key features in pedestrian environments, such as telephone boxes and cash machines, which visually impaired people may have difficulty locating.

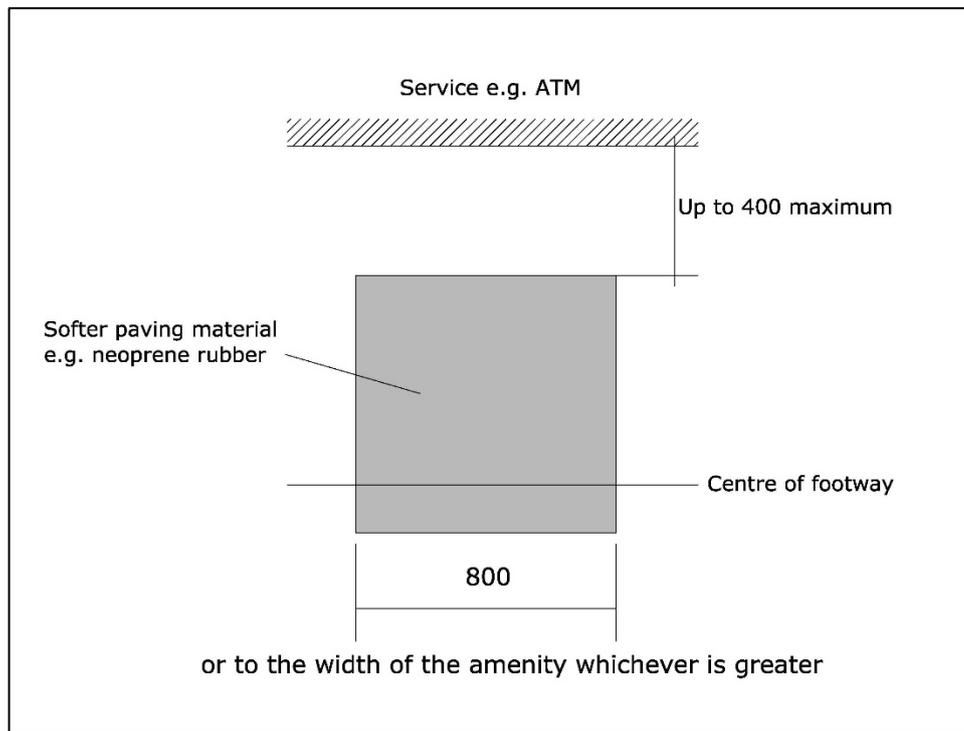

Figure 24: Information surface

## 4.5 Street Furniture/Ancillary Equipment

### 4.5.1 Introduction

This section describes the key inclusive design elements in the design of street furniture and ancillary equipment.

### 4.5.2 Street Furniture

There is a wide range of different types of street furniture, from lighting columns and litterbins to wheeled bins, bollards and sign poles. Most street furniture is necessary but often items of furniture such as lighting columns and sign poles are left behind long after they become redundant. Badly sited furniture is an obstruction to people with mobility impairments and people with visual impairments. Free-standing items, such as bollards, are a particular problem for visually impaired people.

Badly designed street furniture can also pose a hazard to visually impaired people. Furniture lower than 1000 millimetres such as benches without backrests and low bollards are not in most adults normal line of sight. In addition, all street furniture should be detectable at ground level with a long cane. Projecting litterbins fixed to lighting columns and the glazed side walls of cantilevered bus shelters are obvious examples of street furniture which break this rule.

Visually impaired people who receive mobility training, including guide dog and long cane users, are trained to walk in the middle of a footway since there are normally less obstructions in this zone. Visually impaired people move towards the kerb edge or the back of the footway when looking for a crossing or building entrance respectively. Guide dog users and people with mobility impairments, particularly wheelchair users,

require a minimum width of footway to allow them to move easily along a route. Refer to Section 4.1.10 for the minimum footway width between obstructions.

‘Inclusive Mobility’ describes how items of street furniture should be grouped together where possible to assist visually impaired people to identify the potential hazard. This document also describes how colour, including the use of coloured banding, can be used to help avoid collisions with street furniture.

For visually impaired pedestrians relying on residual vision, it is essential to ensure that the colour of street furniture contrasts with its surroundings. Colours which appear to be different from one another in colour (chroma) can be very similar tonally (e.g. green and brown) and therefore do not give sufficient contrast. Contrast is the visual perception of one element when viewed against another and is indicated by the difference in light reflectance between two surfaces. It is generally recognised that 30 points of difference in light reflectance between surfaces should give adequate contrast to be noticeable to a large proportion of partially sighted people. However, the research on this subject was undertaken inside buildings where light levels can be more easily controlled. The level of light shining on a surface has a large influence on the visual perception of contrast, too low or too high a light level can greatly reduce the perception of contrast between colours. Light levels outdoors obviously vary greatly. Therefore, higher differences in light reflectance value than 30 points would be preferable.

To specify suitable colours for new schemes designers should establish the light reflectance value of the street furniture with the manufacturer. As a rule of thumb, for existing street furniture, an adequate contrast will show up on a black and white photograph or a photocopy of a colour photograph, poor contrast will show up as shades of grey. For further information on the use of colour reference should be made to ‘Colour, Contrast & Perception - Design Guidance for Internal Built Environments’ (University of Reading, 1997) and BS 8300.

All unnecessary and redundant street furniture should be removed from footways as part of routine maintenance. All necessary street furniture should be at least 1000 millimetres high and should be grouped together at the back of the footway where possible and out of the main pedestrian flow. Street furniture which is in or close to the pedestrian flow and particularly freestanding furniture in this zone must contrast tonally with its surroundings.

In most circumstances guardrails are not specifically an accessibility feature and railings can be a hindrance to disabled people. These rails can narrow the pedestrian route and can present a hazard to visually impaired people. Wheelchair users, children and people of short stature can be hidden behind street furniture which emphasises the importance of drivers being able to see through railings. For these reasons there must be 2000 millimetres between parallel guardrails and guardrails should be at least 1000 millimetres and ideally 1200 millimetres above ground level. Guardrails must extend to within at least 200 millimetres of the ground, to assist visually impaired people to detect this feature with a long cane.

'Inclusive Mobility' states that guardrails should contrast in tone with their surroundings and for this reason simple galvanised or black painted rails would be unacceptable. However, Transport Scotland considers that finishing guardrailing in a contrasting colour to their surroundings would be aesthetically unacceptable in many settings. Therefore, provided guardrails are sited appropriately only the ends of the guardrailing should be highlighted where they project into the pedestrian flow. The ends of the railings must be highlighted with two 150 millimetre deep bands which contrast tonally with the colour of the railing. By grouping other furniture with a larger profile, such as fixed litterbins, at the ends of guardrailing, the collision hazard of the ends of railings can be minimised.

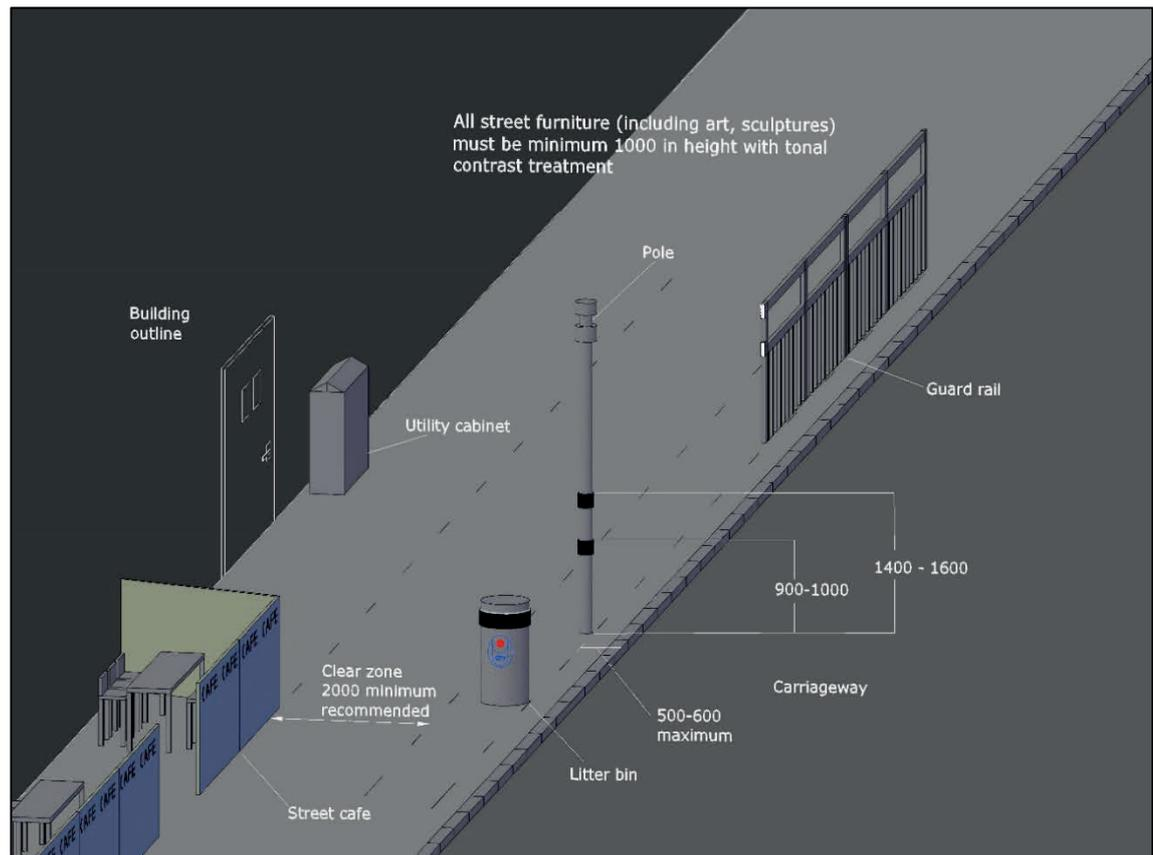

Figure 25: Street furniture

#### 4.5.3 Designing for Tonal Contrast

Existing street furniture must also provide sufficient tonal contrast and the application of a tonally contrasting treatment will be required. This can be achieved, as a minimum, using 150 millimetre deep colour bands which contrast in tone with the colour of the furniture. Bollards and low furniture must have a single band at 1000 millimetres above ground level. Taller items of furniture such as bus shelters and lighting columns must be highlighted with two bands, one at 900 - 1000 millimetres and the other at 1400 - 1600 millimetres measured from ground level to the top of the band. In the case of glazed screens, such as those found on bus shelters, two coloured bands should also be provided. The colour chosen for the highlighting on glazing should contrast with the background against which it will be viewed.

In the design of new schemes or for the installation of new items of street furniture, tonal contrast must be a key element of the aesthetic design of materials and finishes. Integrated into the design process, a broader range of aesthetically pleasing design can

be achieved. Designers should not be restricted to using the 150mm banding which is the minimum vertical dimension required. Where appropriate for example, the banding could take the form of a logo or emblem such as could be applied to a glass screen at a bus stop.

#### 4.5.4 Seating

Many ambulant disabled people cannot walk for more than 50 metres before taking a rest and suitable seating at regular intervals is a particularly important feature in the pedestrian environment. Seats with backrests should be provided at regular intervals along well used pedestrian routes. Seating should generally be 450 – 480mm high, a height most people can rise from, but at bus stops and other locations where people wait for a short period of time “perch” seats can be provided. ‘Inclusive Mobility’ recommends a height of 580mm for this type of seating. At least a proportion of seating in a group should be fitted with armrests to assist in rising from the seat. However, to allow wheelchair users to transfer on to fixed seating, not all seats should have armrests, i.e. there should be no armrest on the end of a row of seats. A space should be kept clear next to fixed seating to accommodate wheelchair users.

#### 4.5.5 Signage

The specification of road signs for drivers is explained within the ‘Traffic Signs Manual’ (Department for Transport, 2006) and the Traffic Signs Regulations and General Directions 2016 (TSRGD). ‘Inclusive Mobility’ contains more information on the design of signage for pedestrians. This information is based on the ‘Sign Design Guide’, (Sign Design Society) and guidance from North America. The principles of clear signage are explained in the document, including the use of colour to highlight the sign from its background and to highlight the text on the sign and the need for upper and lower case lettering rather than all capitals. To enable a sign to be located on both light and dark backgrounds, a border can be incorporated on the sign, rather than changing the colour of the sign board. The guidance also includes a table of text heights suitable for different viewing distances.

Only around 5 per cent of visually impaired people have no sight at all. The vast majority have some residual vision, and may be able to distinguish colours, or shades of light and dark. By making a sign clear and easy to read for a visually impaired person it will make the sign clear and easy to read for most people.

Sign poles and cantilevered signs can present a barrier and a hazard to disabled people and the points made earlier concerning the position of street furniture and minimum footway widths must be applied.

The lack of the minimum distance between poles on double pole signs, and the lack of colour contrast to highlight sign poles is an important issue for partially sighted people.

Where signage aimed at pedestrians is not covered by the ‘Traffic Signs Manual’ or TSRGD, signage should follow the guidance in ‘Inclusive Mobility’ and the ‘Sign Design Guide’. Authorisation will be required for non-prescribed signs.

#### 4.5.6 Lighting

BS 5489:2003 is the code of practice for road lighting. The illumination of the pedestrian environment is often neglected. ‘Inclusive Mobility’ describes the recommendations of BS 5489 and includes a table of light levels for different areas.

Lighting columns can obstruct the footway and present a hazard to visually impaired people. Therefore, columns must be located outwith the footway or if necessary at the back of the footway. In existing locations, columns should be sited consistently either at the back or front of the footway. To reduce clutter at street level in urban areas, new light fittings should, where practical, be fixed to buildings.

All new and replacement lighting schemes for pedestrian areas must meet the criteria described in 'Inclusive Mobility', in addition to BS 5489.

#### 4.5.7 Rest Areas

There are a number of rest areas on the road network where facilities, such as parking, picnic areas and toilets are provided. The design of new facilities and upkeep of existing facilities must consider the needs of disabled people, alongside the needs of all other users, to meet the commitment to disability equality.

TD 69/07 (DMRB 6.3.3) describes rest areas as all sites on motorways or all-purpose trunk roads that provide parking and an associated picnic area. They may also provide some, but not all, of the facilities normally associated with a service area.

In addition to the inclusive design of the road infrastructure described in this Guide, the design of all features contained within the rest area site should adhere to inclusive design principles.

#### 4.5.8 Parking

'Inclusive Mobility' gives clear guidance on the proportion of parking spaces which should be provided for vehicles carrying disabled people and on the design of these spaces. Accessible parking spaces should be sited on level areas with little or no cross-fall, as close as practicable to any amenities. Signage and street furniture should be kept clear of parking spaces and placed at the rear of the surrounding footway. Road markings must be in accordance with TSRGD – yellow road markings may be used for off-street parking spaces.

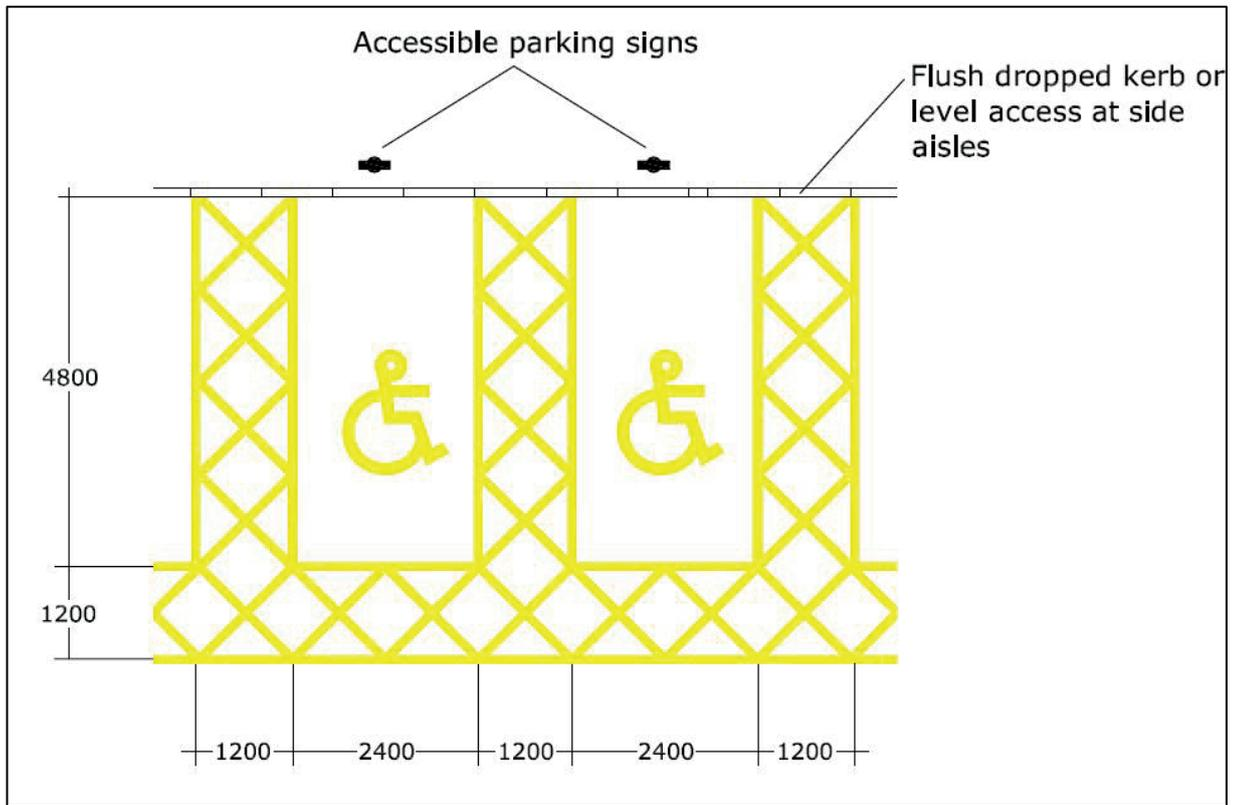

Figure 26 a: Accessible off-street parking spaces (e.g. in rest area)

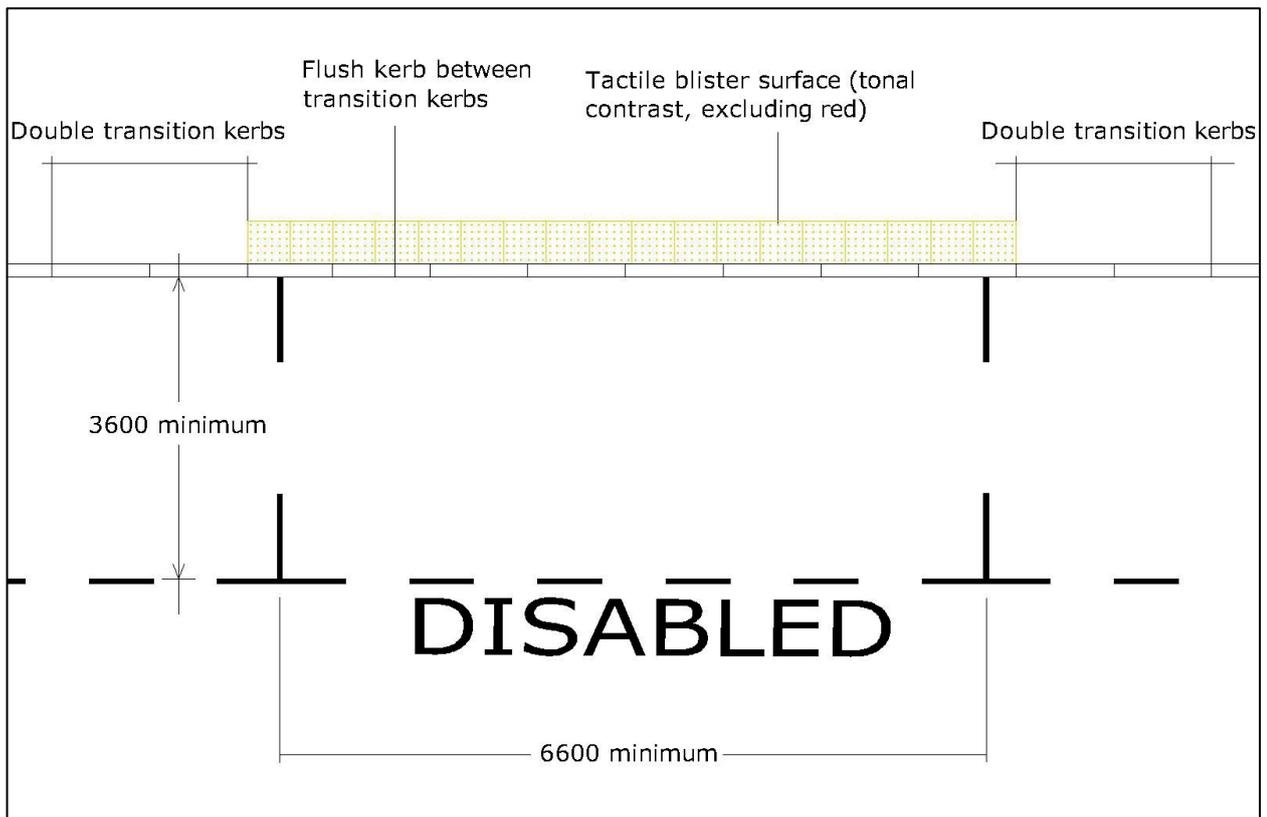

Figure 26 b: Accessible on-street parallel parking space (e.g. in town centre)

4.5.9 Toilets

One of the most common forms of disability is incontinence and a lack of suitable toilet facilities prevents many disabled people and their families making journeys. Therefore, wherever possible rest areas should include toilet facilities. If there is only space to accommodate one toilet it should be a unisex accessible toilet. The accessible toilet should be designed to the standard set out in BS 8300. The provision of “Changing Places” toilets should be considered for larger rest and service areas.

These facilities are designed to accommodate disabled adults who require assistance in using the toilet and those who require assistance to change. See <http://www.changing-places.org/>.

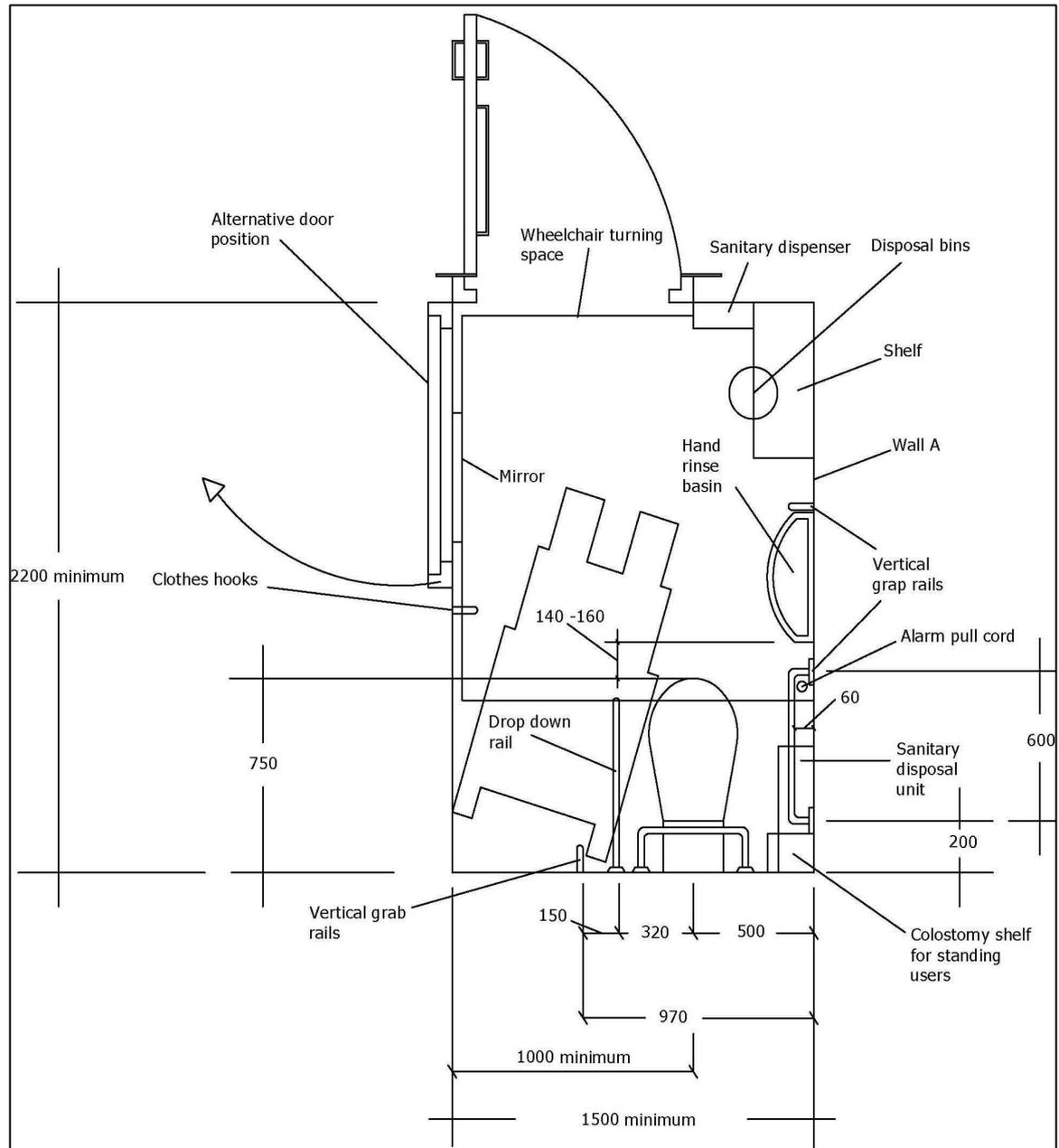

Figure 27: Accessible toilet - plan

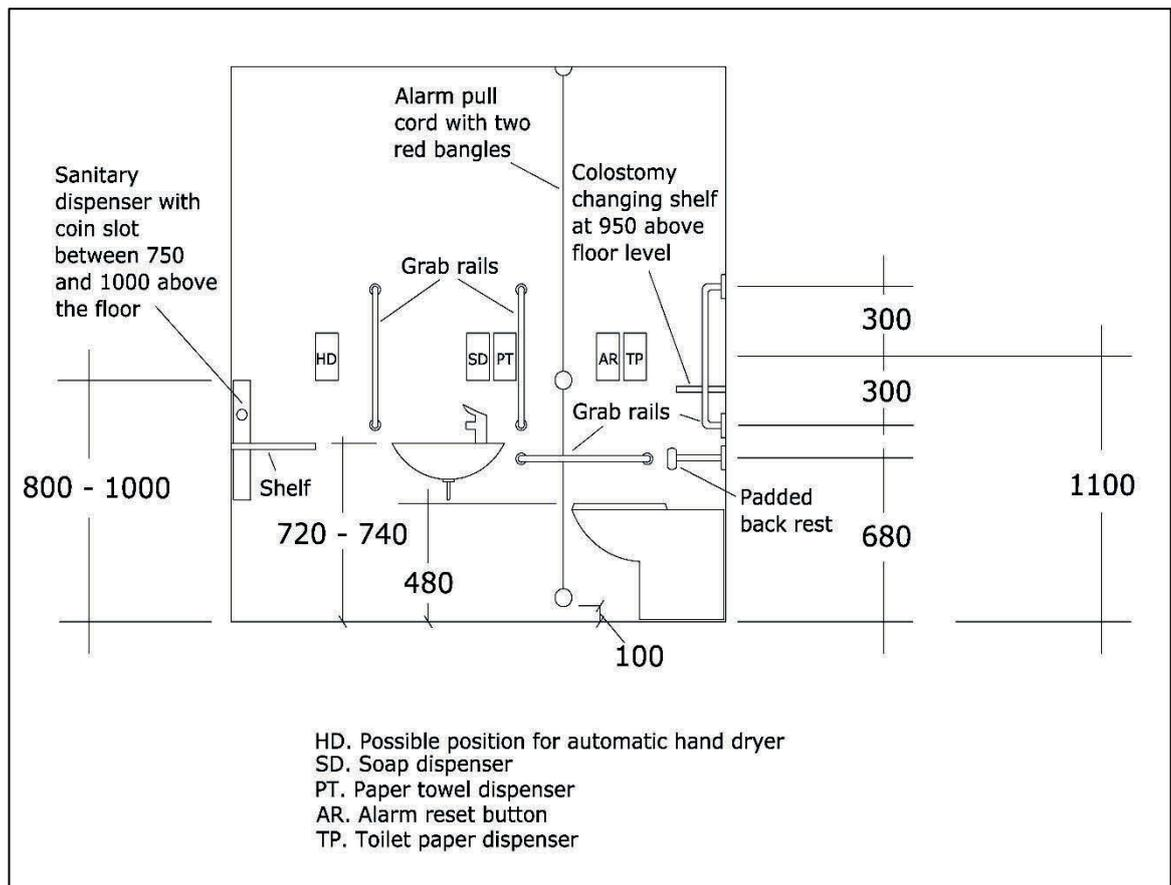

Figure 28: Accessible toilet – elevation

#### 4.5.10 Emergency Telephones

It is important that everyone must be able to reach and use an emergency telephone. In this regard, the location of the phone is just as important as the design of the installation.

A level hard standing/plinth of 1800 x 1800 millimetres minimum (1500 x 1500 millimetres absolute minimum) must be provided adjacent to the phone installation to allow wheelchair users to manoeuvre up to the phone and to turn around before returning to their vehicle. In addition, a person may have a weakness on one side and therefore being able to turn round to use the phone is essential. A flush dropped kerb arrangement should also be provided to allow access to the plinth from the carriageway. A raised kerb should be provided along the exposed edge of the plinth where the plinth is raised above the ground or where the ground falls away, such as when an emergency phone is located on the edge of an embankment.

The phone controls should be in the range of 900 and 1100 millimetres in height from the ground providing a reasonable level of access for most users.

The following drawings show the layout of the emergency phone located within an emergency lay-by and on a motorway with hard shoulder, and where TD 19/06 (DMRB 2.2.8) describes the arrangement for accommodating an emergency telephone where a safety barrier is present.

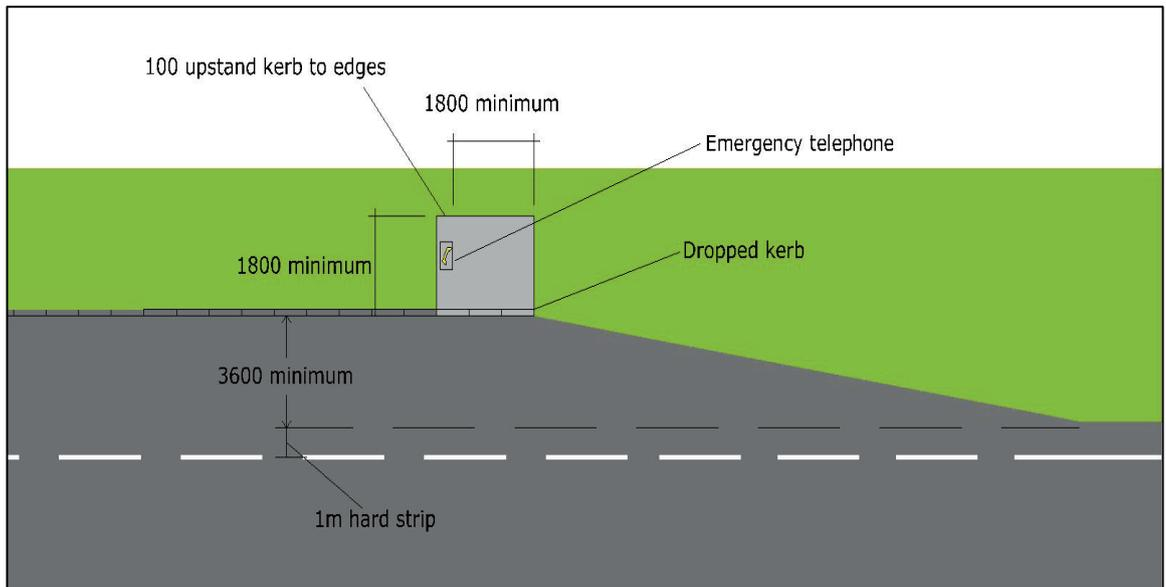

Figure 29: Emergency telephone in emergency lay-by (no barrier or footway)

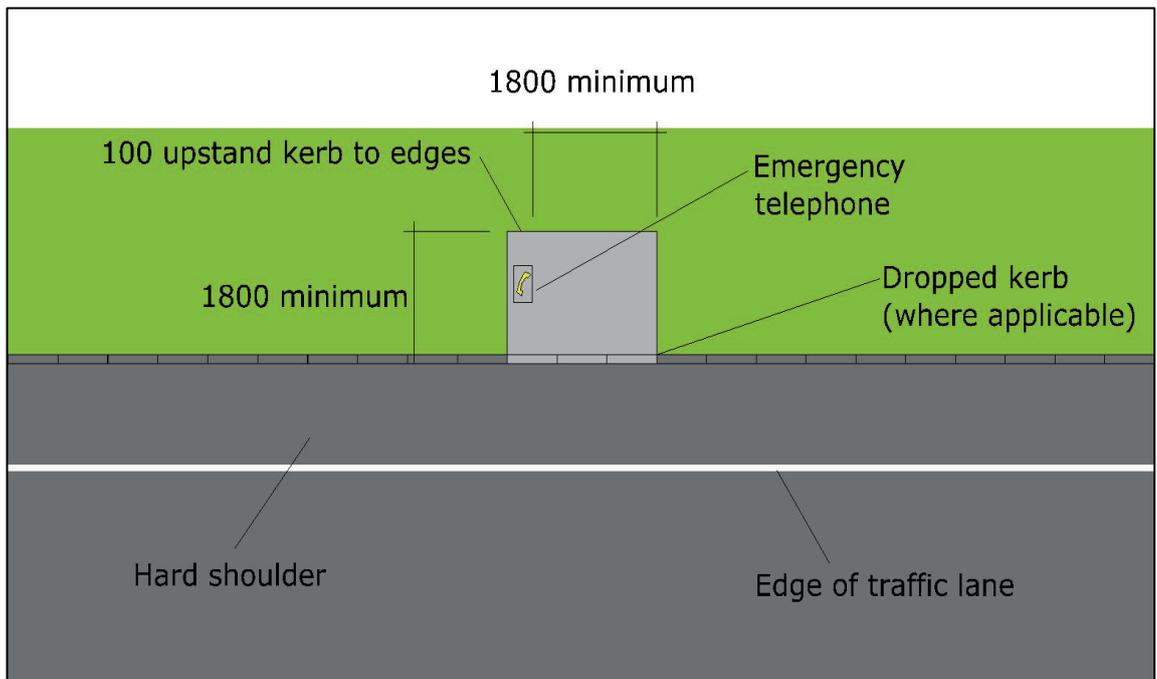

Figure 30: Emergency telephone on hard shoulder (no barrier)

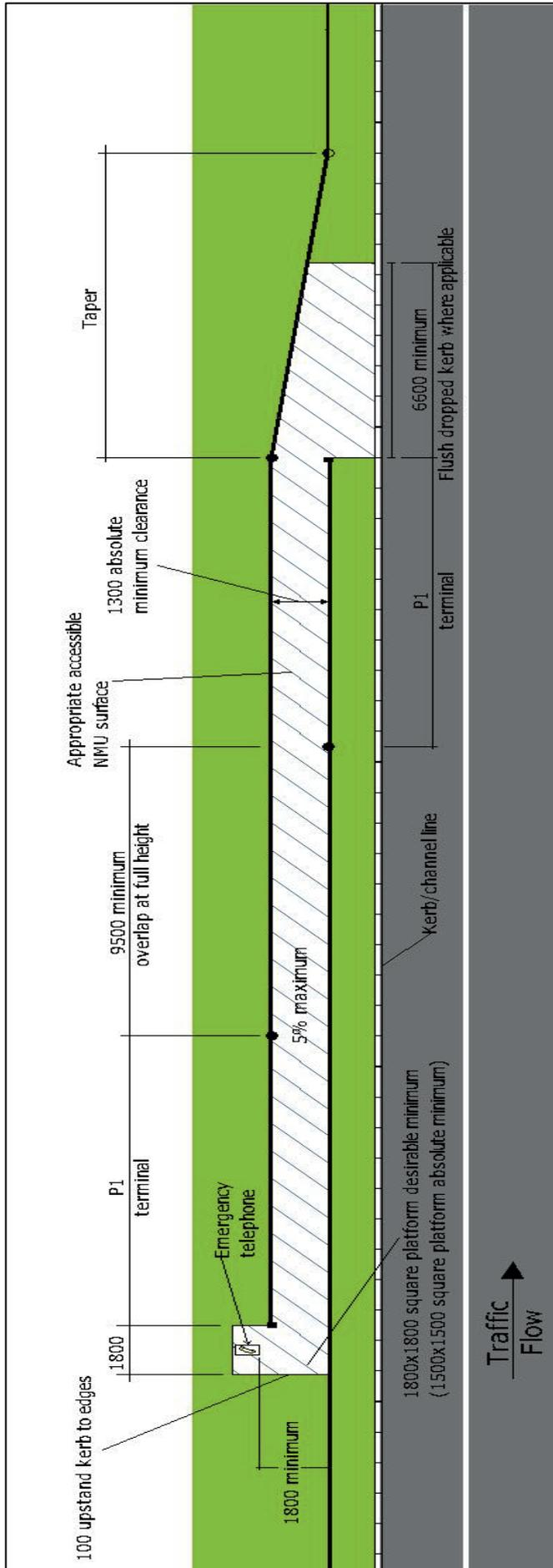

Figure 3 I: Accommodating emergency telephone at verge safety barrier

Page intentionally left blank

# CONSTRUCTION, OPERATION AND MAINTENANCE

## 5.1 Introduction

The pedestrian environment can become difficult or even dangerous for many disabled people to use during construction, operation and maintenance works. Those responsible for such undertakings are required to implement the following advice.

## 5.2 Construction

### 5.2.1 Traffic Management

Reference should be made to the 'Traffic Signs Manual' Chapter 8 Part 1: Design and Part 2: Operations, and in particular:

Section O3.13.6 highlights the need to consider people with visual impairments, people with mobility impairments including wheelchair users and parents with prams during road works. Protection for people with a visual impairment will require that road works sites should be guarded on those sides accessible to pedestrians. The need for guarding is not necessarily restricted to the footway side of the works. Provision may need to be made for people crossing the road including dropped kerbs. There must be a pedestrian barrier which is readily detectable by a visually impaired person using a long cane; see Section O4.11.6 and Part 1: Design, Section D3.10. The guarding should include a lower tapping rail at a maximum of 200 millimetres above ground level as well as a higher rail at 1000 millimetres to 1200 millimetres.

Section O4.11.6 highlights the need to give particular attention to the needs of people with visual impairments. A pedestrian barrier should be provided on those sides of an obstruction that restrict pedestrian flow or are accessible to pedestrians, regardless of whether or not visually impaired pedestrians are known to use the route.

### 5.2.2 Traffic Management Design

When designing temporary traffic management measures, the guidance contained below and in the 'Traffic Signs Manual' Chapter 8 is to be followed in all circumstances. Particular attention should be directed to the needs of visual and mobility impaired pedestrians when designing and operating pedestrian diversion routes. Reference should be made to the design standards in the Good Practice Guide as an "aide-mémoire" to the needs of mobility and visually impaired users.

In particular:

- The need for the provision of an even surface for the diversion route and provision of temporary crossing facilities. This includes the need to provide dropped kerbs to maintain the integrity of a route for wheelchair users and parents with prams.
- Where pedestrians are diverted to the adjacent footway consideration must be given to the location of the diversion route and how both visually and mobility impaired users will be able to cross the road in a safe manner. Where a route must be narrowed, such as when scaffolding is erected, minimum footway widths must be maintained.
- Closing a footway mid-block and diverting pedestrians to the opposite footway is common but is not conducive to an inclusive environment. A suitable inclusive

diversion route must always be provided. Involvement of the local Access Panel can be useful in the design of temporary pedestrian management.

- Where a long diversion route is proposed, the design must make sure that visual and mobility impaired users can use the diversion route, and that no barriers to movement will be encountered.

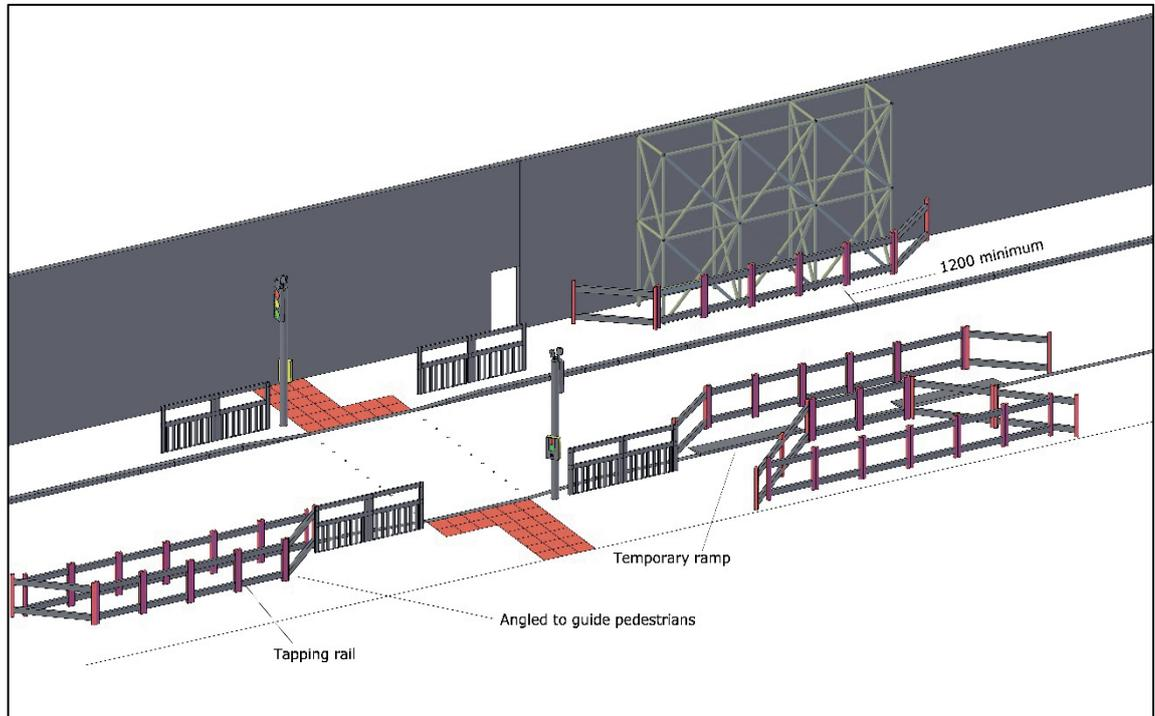

Figure 32: Traffic management

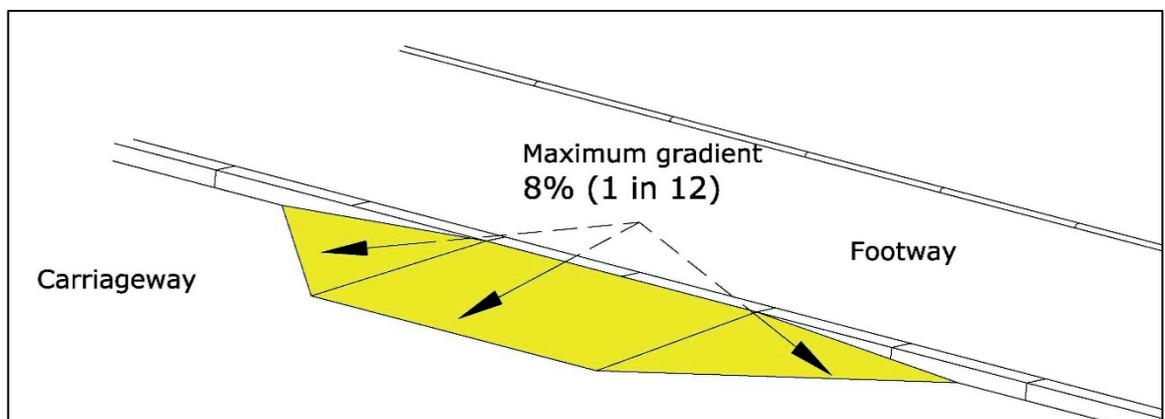

Figure 33: Temporary dropped kerb/ramp

### 5.2.3 Construction Quality Control

Attention to quality control during the construction period is essential to avoid hazards which may be difficult or costly to remedy during normal maintenance. The following are examples of common barriers in the field:

- Service covers not flush with footway;
- Wide joints in the footway;
- Footway surface irregularity;
- Gratings placed in the line of pedestrian crossing points.

## 5.3 Operational Issues

### 5.3.1 Advertising Boards

Shop owners should be made to remove illegal advertising boards from the footway. This type of obstruction is particularly difficult for visually impaired people to detect, since these are free standing and not always in the same place every day. Once one shop owner puts an advertising board on the street there is a tendency for other traders to follow suit. On narrow footways these boards can create a “slalom” effect which is difficult for pedestrians to negotiate. Guidance should be obtained from the relevant local planning and roads authorities with respect to local advertising policies.

If a display on private land cannot be removed, Transport Scotland will encourage the following good practice to minimise obstruction:

- A minimum 2000 millimetres wide obstacle-free passageway is retained;
- The board is not repositioned from day to day ;
- There is no more than one board at each frontage;
- Pedestrians are not forced into the carriageway, either directly or because of the numbers of pedestrians attempting to walk around the board;
- The board is solidly constructed so that it does not collapse if inadvertently knocked;
- The board does not have any projections, sharp edges, rotating parts or places where fingers and clothing could become trapped;
- The minimum height of the board is 1000 millimetres;
- The board is brightly coloured to contrast with the background against which it is seen and incorporates contrasting colours/tones.



Figure 34: Example of A-boards obstructing the footway

### 5.3.2 Pavement Cafés

A well designed pavement café, in the right location, can add value to the pedestrian environment and should present no barriers or hazard to disabled people. However, a badly designed café or a café on too narrow a footway can restrict the pedestrian route and create a hostile environment for disabled people. Therefore, there must be strict controls on where pavement cafés are allowed and what café furniture is used. As with shop advertising boards, café furniture should be removed from poorly designed pavement cafés, in the wrong location and from cafés that are badly managed. Guidance should be obtained from the relevant local planning and roads authorities with respect to local policies.

Pavement cafés should be located adjacent to the building frontage so that staff and customers are not required to cross the line of pedestrian travel. A minimum clear passageway of 2000 millimetres on busy streets and 1800 millimetres on streets with low pedestrian flows, should be maintained at all times and this should be free of other obstructions such as street furniture.

The street café should be surrounded on all sides by a continuous physical barrier at least 1000 millimetres high, for example continuous planters or railings, which should contrast with the background to aid detection by partially sighted people. To be detectable by long cane users, the barrier should be continuous to the ground or, alternatively, incorporate a lower rail which should be no higher than 200 millimetres above ground level. The barriers should not contain sharp edges or protruding parts and all furniture and displays should be contained within the guarded area.



Figure 35: Example of a well designed pavement café

### 5.3.3 Projections

Projections on to the footway, such as outward opening doors, windows and shop canopies, from properties adjoining the road network should be carefully controlled.



Figure 36: Example of an acceptable projection over a footway

### 5.3.4 Obstructing the Footway

Cars overhanging the footway or parked on the footway reduce the effective width for pedestrians to the extent that in some circumstances pedestrians must use the road, which is dangerous particularly for vulnerable pedestrians. If there are no dropped kerbs available this obstruction may prevent wheelchair users from making a journey. Visually impaired pedestrians often find it difficult to detect cars on or overhanging the footway, where they least expect them to be. Driving on the footway and obstructing the footway is illegal and should be brought to the attention of the police for enforcement purposes.

### 5.3.5 Unauthorised Use of Accessible Bays

Unauthorised parking in accessible bays is a particularly common problem. The Disabled Persons' Parking Places (Scotland) Act 2009 enables legal enforcement of disabled parking places. The Act imposes a duty on local authorities to exercise its power to make an order under either section 45 (on-street parking places) or section 35 (off-street parking places) of the Road Traffic Regulation Act 1984. All accessible parking bays must therefore be accompanied by a Traffic Regulation Order, currently administered by local authorities.

## 5.4 Maintenance

### 5.4.1 Foliage

Overhanging branches and foliage can reduce the effective width of footways and present a serious hazard to visually impaired pedestrians. Visually impaired people have difficulty detecting anything above waist height with a long cane and a guide dog can walk underneath this type of hazard. Branches overhanging a footway fall into this hazard category and can cause a serious injury to eyes and face. Vegetation must be cut back to maintain a clear head height above footways and allow for the growth of the tree or bush. Holly bushes and other vegetation with sharp barbs are not suitable for footway locations and should be removed.



Figure 37: Example of footway with well maintained foliage

### 5.4.2 Footway Surfaces

Uneven and broken paving can present a trip hazard to pedestrians. Footway surfaces should be checked regularly and broken and uneven surfaces should be repaired.



Figure 38: Good example of level footway surface

---

## Appendix A – Equality Impact Assessment and Test of Reasonableness - guidance for Project Teams

### **Equality Impact Assessment (EqIA)**

Equality Impact Assessment (EqIA) is all about considering how our activities, functions, projects, strategies, programmes, services or processes may impact, positively or negatively, on different sectors of the population in different ways.

In terms of good practice in road design, construction and operation, the Scottish Government's EqIA helps identify who these people may be and what specific needs they may have. If your work affects people in any way, you have a responsibility to make sure you know how it affects different groups of people. More than that, you have a statutory duty to consider and address the impact of your project on particular groups (disabled people, women and men and different ethnic groups). In addition to these statutory responsibilities the Scottish Government also has a commitment to promote equality in the areas of religion and belief, age and sexual orientation.

The Scottish Government's EqIA guidance and assessment tool is accessed through the following web link:

<http://www.gov.scot/topics/people/equality/18507/EQIAtool>

It must be used in assessing the positive and negative impacts on disabled people in all new design, construction and operational works on the trunk road network to assist in avoiding, mitigating or providing compensatory measures to alleviate the impact where it is reasonable to do so, always remembering that we have a statutory duty (a) to be non-discriminatory in undertaking our functions and (b) to promote disability equality.

### **Removing Barriers from the Road Network**

All new roads projects and improvements including maintenance and other renewal works must be designed to the Standards set out in this Good Practice Guide and opportunities to promote access for disabled people must be considered from the beginning of the design process for every new scheme. However, as Trunk Road Authority, Transport Scotland also has a statutory obligation to make reasonable adjustments to any existing restrictions or barriers that disabled people face in using the trunk road network. In this regard the existing trunk road network contains many features that impact upon the ability of disabled people to use the network to access services, employment or simply to reach their local shop independently.

To ensure that public resources are used effectively there is a requirement to subject proposals to remove existing barriers to a Test of Reasonableness. A methodology has been developed to establish what works would be considered "reasonable" to carry out and what works would not. The methodology is based on the Scottish Government's social, economic and environmental objectives and is as set out below.

**Cost / Environmental Impact**

<b>High</b>	<b>Consult local Access Panel *</b>	<b>Consult local Access Panel *</b>	<b>Apply GPG standards</b>
	<b>Consult local Access Panel *</b>	<b>Apply GPG standards</b>	<b>Apply GPG standards</b>
	<b>Apply GPG standards</b>	<b>Apply GPG standards</b>	<b>Apply GPG standards</b>
<b>Medium</b>	<b>Consult local Access Panel *</b>	<b>Apply GPG standards</b>	<b>Apply GPG standards</b>
<b>Low</b>	<b>Apply GPG standards</b>	<b>Apply GPG standards</b>	<b>Apply GPG standards</b>
	<b>Low</b>	<b>Medium</b>	<b>High</b>

**Social / Economic Benefit**

**Cost / Environmental Impact # Social / Economic Benefit †**

<b>High</b>	<b>&gt; £50,000</b>	<b>High</b>	<b>&gt; 100 users per day</b>
<b>Medium</b>	<b>£10,000 - £50,000</b>	<b>Medium</b>	<b>50 – 100 users per day</b>
<b>Low</b>	<b>£0 - £10,000</b>	<b>Low</b>	<b>0 – 50 users per day</b>

\* **Access Panel directory** – see [www.accesspanelnetwork.org.uk](http://www.accesspanelnetwork.org.uk)

# **Environmental Impact** as defined in ‘**Scottish Transport Appraisal Guidance**’ (Scottish Government, 2008)

† **Assumes that 20% of users will be disabled** (as per general population)

---

## Appendix B – Further References

### Further Reading

*Design Manual for Roads and Bridges (The Stationery Office)*

This UK road engineering document focuses on the design of road schemes and is one of the main influences of this Good Practice Guide. This document is the industry standard in the planning, design, and delivery, of road schemes and is aimed at road design engineers.

*Inclusive Mobility (Department for Transport, 2005)*

This document describes a process for ensuring the needs of disabled people are included within the design of transport infrastructure, and is one of the main influences of this Good Practice Guide.

*Guidance on the Use of Tactile Paving Surfaces (Department for Transport, 2005)*

This document provides guidance on the use of dropped kerbs and tactile surfaces at pedestrian crossing points and recommends the type of tactile surface arrangement to be adopted at different types of pedestrian crossings.

*Inclusive Projects (Disabled Persons Transport Advisory Committee, 2003)*

This document describes a process for ensuring the needs of disabled people are included within the design of projects. The document is primarily targeted at buildings rather than road construction. However, most of the principles described in the document apply equally to road projects.

*Designing Streets (Scottish Government, 2010)*

This document focuses on the design of lightly trafficked streets to redress the balance between vehicles, pedestrians and other road users. Some trunk roads could be described as streets but their primary function is traffic movement. Many of the principles described within the document would assist disabled and older people and may be appropriate to apply to certain trunk road schemes, especially on routes running through towns and villages.

*Cycling By Design (Scottish Government, 2011)*

This document focuses on the design of new cycling infrastructure however it represents a reference document for the design of new infrastructure used by all non-motorised forms of transport.

*Making Transportation Accessible – A Canadian Planning Guide (Transport Canada, 1998)*

This document considers all the aspects of making transport accessible to disabled and older people and records the experience and good practice from Canada. This strategic document is aimed at transport planners, designers, manufacturers and operators.

*Local Transport Note LTN 1/11 Shared Space (Department for Transport, 2011)*

This document sets out various considerations in the development of a shared space design with particular emphasis on stakeholder engagement.

## Reference Documents

*Roads for All – The Trunk Road Network Disability Equality Scheme and Action Plan* (Transport Scotland, 2006)

<https://www.transport.gov.scot/media/5738/roads-for-all-revised.pdf>

*Scottish Executive's Disability Equality Scheme* (Scottish Executive, 2006)  
ISBN 978 0 7559 5223 6

*Improved Public Transport for Disabled People* (Scottish Executive, 2006)  
ISBN 0 7559 6033 5

*Older People: Their Transport Needs and Requirements* (Department for Transport, 2001)

*Inclusive Mobility* (Department for Transport, 2005)

[https://www.gov.uk/government/uploads/system/uploads/attachment\\_data/file/3695/inclusive-mobility.pdf](https://www.gov.uk/government/uploads/system/uploads/attachment_data/file/3695/inclusive-mobility.pdf)

*Guidance on the Use of Tactile Paving Surfaces* (Department for Transport, 2005)

[https://www.gov.uk/government/uploads/system/uploads/attachment\\_data/file/3622/tactile-pavement.pdf](https://www.gov.uk/government/uploads/system/uploads/attachment_data/file/3622/tactile-pavement.pdf)

*Colour, Contrast & Perception - Design Guidance for Internal Built Environments* by Keith Bright, Geoff Cook, John Harris (University of Reading, 1997)  
ISBN 0 70491 2082

*Sign Design Guide* by Peter Barker, June Fraser (The Sign Design Society)  
ISBN 185878 4123

*Cycling By Design* (Scottish Government, 2011)  
ISBN 978 1 906006 68 6

*Designing Streets* (Scottish Government, 2010)  
ISBN 978 0 7559 8264 6

*Traffic Signs Manual* (Department for Transport, 2006)  
ISBN 978 0 11 550 559 1

*Scottish Transport Appraisal Guidance* (Scottish Government, 2008)  
ISBN 978 1 906006 27 3

*Puffin Crossings Good Practice Guide* (Department for Transport, 2006)

<http://assets.dft.gov.uk/publications/puffin-good-practice/puffin-good-practice-guide.pdf>

Further copies of this document are available, on request, in audio and large print formats and in community languages (Urdu; Bengali; Gaelic; Hindi; Punjabi; Cantonese; Arabic; Polish).

اس دستاویز کی مزید کاپیاں آڈیو کیسیٹ پر اور بڑے حروف کی چھپائی میں اور کمیونٹی کی زبانوں میں طلب کیے جانے پر دستیاب ہیں، برائے مہربانی اس پتے پر رابطہ کریں:

এই ডকুমেন্ট-এর (দলিল) অন্তর্ভুক্ত কপি, অডিও এবং বড়ো ছাপার অক্ষর আকারে এবং সম্প্রদায়ের ভাষায় অনুরোধের মাধ্যমে পাওয়া যাবে, অনুগ্রহ করে যোগাযোগ করুন:

**Gheibhear lethbhreacan a bharrachd ann an cruth ris an èistear, ann an clò mòr agus ann an cànan coimhearsnachd. Cuir fios gu:**

इस दस्तावेज़/कागज़ात की और प्रतियाँ, माँगे जाने पर, ऑडियो टैप पर और बड़े अक्षरों में तथा कम्युनिटी भाषाओं में मिल सकती हैं, कृपया संपर्क करें:

ਇਸ ਦਸਤਾਵੇਜ਼/ਕਾਗਜ਼ਾਤ ਦੀਆਂ ਹੋਰ ਕਾਪੀਆਂ, ਮੰਗੇ ਜਾਣ 'ਤੇ, ਆੱਡਿਓ ਟੇਪ ਉੱਪਰ ਅਤੇ ਵੱਡੇ ਅੱਖਰਾਂ ਵਿਚ ਅਤੇ ਕੰਮਿਊਨਿਟੀ ਭਾਸ਼ਾਵਾਂ ਦੇ ਵਿਚ ਮਿਲ ਸਕਦੀਆਂ ਹਨ, ਕ੍ਰਿਪਾ ਕਰਕੇ ਸੰਪਰਕ ਕਰੋ:

此文件有更多備份，如果需要，語音版本和大字體版本及少數種族語言版本也可提供，請聯絡:

يمكن أن تطلب النسخ الأخرى من هذا المستند كالتسجيل الصوتي والخط المكبر ونسخ بلغات أخرى، يرجى الإتصال على:

Aby otrzymać niniejszy dokument w innej wersji językowej, na kasecie lub w wersji z powiększonym drukiem, prosimy o kontakt:

Transport Scotland, Buchanan House,  
58 Port Dundas Road, Glasgow, G4 0HF  
0141 272 7100  
[info@transportscotland.gsi.gov.uk](mailto:info@transportscotland.gsi.gov.uk)  
[www.transport.gov.scot](http://www.transport.gov.scot)

© Crown copyright 2013

ISBN: 978-1-908181-72-5

Published by Transport Scotland, July 2013

